







# AUTO LAMITOR Instruction Manual

MODEL NO : HLA-2301

## About the warning mark

The following marks are added to the explanations of things that you should never do or should be careful about in this manual and the main body. Be sure to read these marks and follow the instructions.

	<p><u>General cautions and warnings</u> We will inform you of general cautions and warnings that are not specified.</p>
	<p><u>Caution for electric shock</u> Used for notification to warn of the possibility of electric shock under specific conditions.</p>
	<p><u>Caution for entrapment</u> Used for notification to warn of the possibility of electric shock under specific conditions.</p>
	<p><u>Amputation Caution</u> This is used to notify you of possible obstacles such as amputation of a finger with a sharp rotating object.</p>
	<p><u>High temperature caution</u> Used to notify the possibility of damage due to high temperature under specific conditions.</p>
	<p><u>General prohibitions</u> We will inform you of general prohibitions that are not specified.</p>
	<p><u>Forcibly unplug the power plug from the power outlet</u> Unplug the power plug from the power outlet in case of a dangerous situation such as a malfunction.</p>



## Warning label for safety

In order to indicate the magnitude of danger in each part of this machine, warnings are given in the following two levels.



**WARNING**

...

When it is assumed that the user may be killed or seriously injured if mishandled.



**CAUTION**

...

When it is expected that the user will be seriously injured or only property damage will occur if the product is handled improperly.



## Warning (about installation location)

---

Do not install in such a place. When installing this machine, avoid the following places as it may cause safety problems such as fire, electric shock, and tipping, and may also cause a malfunction.

This equipment is not suitable for use in locations where children are likely to be present.



Places exposed to direct sunlight  
Near the air conditioner outlet



Extremely hot places  
(including near fire, such as heat appliances)



Extremely cold place



Places where the floor is not strong  
Places where the floor is not horizontal  
Places where there is a lot of vibration



Extremely high or low humidity



Dusty place



## Warning (about power supply / ground)

---

### 1. . When using, use the correct power supply voltage . . .

Be sure to take the power supply from AC100 to 240V.

Changing the voltage may cause electric shock, fire, and malfunction. For safety use, please prepare a dedicated outlet.

\* The power plug of this unit is a 3-pin power plug.

### 2. Please allow enough capacity

Make sure there is enough room in the capacity (ampere) of the outlet to be connected. If there is not enough capacity, it may cause malfunction or fire. Never use octopus electrical connection.

### 3. Connect the ground wire

Be sure to connect the ground wire to prevent danger in case of emergency and to prevent troubles from malfunction, electric shock, power supply noise, and static electricity.

This product must be connected to an earthed mains socket-outlet.

### 4. Please take good care of the power cable

Do not place heavy objects on it, pinch it, pull it, or bring it close to heating appliances. If the power cable is damaged, it may cause a fire, electric shock, or malfunction. Also, do not modify cables or plugs.

This product must be connected to an earthed mains socket-outlet.



## Warning (general precautions)

---

Observe the following precautions for safe operation and maintenance of this machine.

### 1. . About clothes at work

Please wear clothes suitable for the work of this machine.

- Avoid ties, necklaces, and hanging accessories.
- Avoid loose clothing. If it gets caught, immediately turn off the power switch (○) or disconnect the power plug.
- Be careful not to pull your hair in.

## 2. When operating this machine

- Be sure to close the cover when operating the machine.
- Do not splash water on the machine or operate it with wet hands.
- Do not leave the machine while operating it.

## 3. When an abnormality occurs in this machine

- If a malfunction or unsafe condition occurs, immediately turn off the power switch (○), disconnect the power plug, and contact the maintenance company or your dealer. Do not disassemble, modify or repair by yourself.
- Service and maintenance are always performed by qualified service personnel, observing the necessary precautions.

## 4. Others

Never do the following as it may cause damage to the machine, death, serious injury, electric shock, fire, etc.

- Do not use for any purpose other than the intended purpose of this machine.
- Do not place heavy objects on the machine or subject it to shocks.
- Be sure to unplug the power plug when moving the unit.
- Be sure to unplug the power plug when moving the unit.
- Please note that handling of dangerous materials or incorrect operation may cause smoke.
- Be careful not to drop metal objects such as clips or staples inside the machine.
- Never remove the fixed cover or safety switch.
- Never modify this unit.
- Use outside Japan is prohibited. There is a possibility of failure or fire due to the power supply voltage.
- Never remove the warning label attached to the inside of the machine.
- Be sure to use our HKK exclusive film.
- Do not do anything else that is not described in the "Instruction Manual" of this manual.



### Caution (for paper that cannot be laminated)

Do not laminate the following:

- Securities and banknotes
- Those with metal parts such as hochikisu
- Ignition, easily meltable in heat (PVC, polyethylene, etc.)
- Important things such as only one sheet
- Thickness of 0.5 mm or more including film
- Items that change color or deteriorate due to heat, such as thermal paper and pictures drawn with crayons
- Those containing a lot of water
- Things other than paper
- Things that are not annoying, such as curves and wrinkles



### Attention (about care)

Be sure to remove the power plug before cleaning the machine. Also, the inside of the machine may be extremely hot, so turn off the power (○) before cleaning, and wait for a while.

Wipe off any dirt with a soft cloth. If it is very dirty, wipe it off with a soft cloth dampened with a small amount of water or a neutral detergent. After using a neutral detergent, be sure to wipe it off with a soft cloth soaked in water only.



## Attention (about the remaining amount of film)

---

This machine has a function to notify the end of the film (film shuryo laminating error). For this reason, we use black film or black tape at the end of the film. When laminating a large amount of paper, pay attention to the remaining amount of film. It may be laminated with black film or black tape.

We recommend that you prepare a little extra paper. We also recommend that you check the remaining amount of film frequently from the film cover.

## Contents

---

1. Confirmation of contents	5
2. Name and function	5
3. Machine installation	8
4. Film set	9
5. Operation procedure	11
6. Various setting methods	13
7. When in trouble	15
8. Machine specifications	18

## 1. Confirmation of contents

---

Before using, please make sure that you have the following contents. Should you find any missing items, please contact your retailer.

- Main unit
- Feeder tray
- Expansion tray
- Stacker
- Power cable
- Instruction manual
- Warranty card
- Garbage box (separate packaging)
- Stand (separate packaging)
- Stand assembly manual (separate packaging)
- Tools (for stand assembly) (separate packaging)
- Screw (for stand assembly) (separate packaging)

## 2. Names and functions of each part

---

### 2-1. Inside the main body

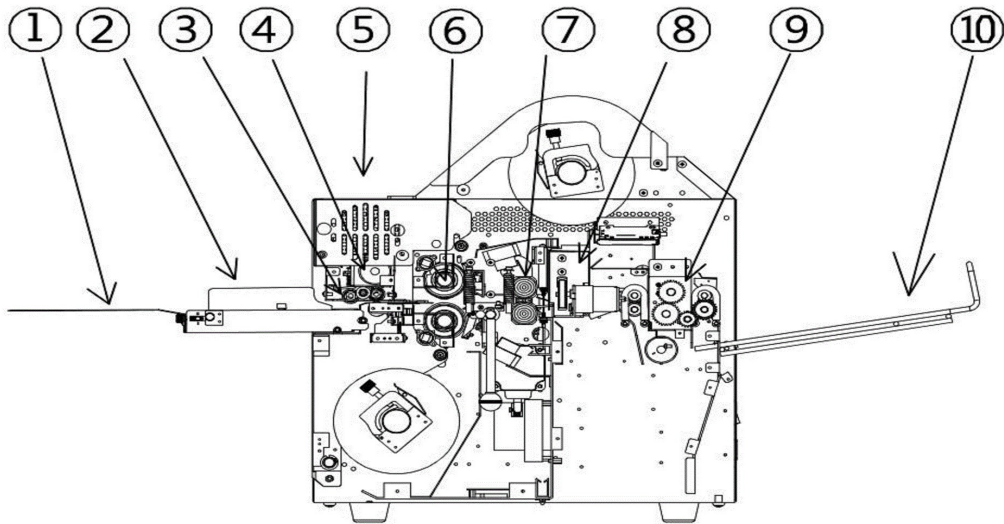

1	Expansion tray	Tray used for A3 size processing
2	Tray	A tray for feeding paper of A4 or smaller size
3	Feeding roll (Sabaki roll)	Roll that pulls in paper one by one
4	Separating roll (Heat roll)	Roll that separates paper one by one
5	Feeder part	Unit part feeds paper one by one
6	Heating roll	Roll for thermocompression bonding the film
7	Full roll	A roll that pulls the thermocompression-bonded film
8	Cutter part	Unit that cuts the film in the front-back
9	Slitter part	direction Unit that cuts the film in the left-right direction
10	Stacker	A tray that collects laminated work pieces

## 2. Names and functions of each part

### 2-2. Operation panel

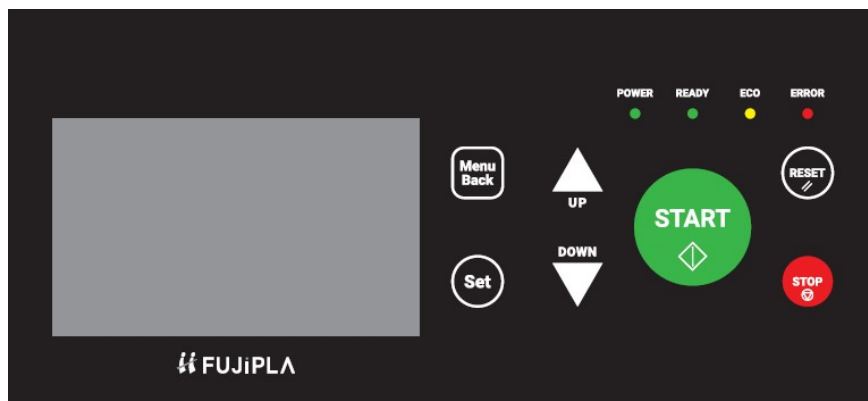

**START** button  
Laminate processing starts.



**STOP** button  
Stops laminating.



**RESET button**

It is used to clear the error and return the setting value to the default.



**UP button**

Used to change the set value.



**DOWN button**

Used to change the set value.



**Menu/Back button**

Moves to the setting mode.



**SET button**

Used to confirm the selection.

**POWER**



**POWER lamp**

Lights when the power of this unit is on.

**READY**



**READY lamp**

Lights when it is ready for laminating.

This lamp lights up when the set temperature is reached.

**ECO**



**ECO lamp**

Lights when in eco mode.

**ERROR**



**ERROR lamp**

Lights when an error occurs.



**Liquid crystal Display**

Displays the status of this unit. For details, refer to 2-4. Liquid crystal display.

## 2. Names and functions of each part

---

## 2-3. Other operation switches

There is a switch on the slitter inside the main body where the operation panel is installed.

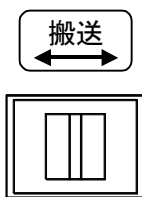
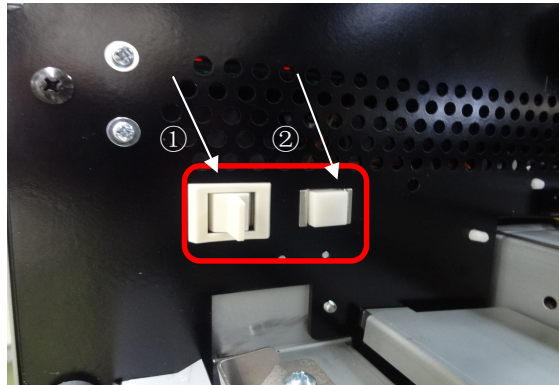

### ① Manual transport switch

Used when setting the film.

When the switch is tilted to the left, it will be transported in the forward rotation direction. Tilt the switch to the right to transport it in the reverse direction.

\* When using, set the slitter adjustment knob to the position where the film is set.



### ② Manual cut switch

Used when setting the film.

\* Cannot be used continuously. It does not work at the time of cut error.

### Warning

- The manual switch operates regardless of the state of the unit, so please take sufficient safety precautions when using it.

※ When operating the manual transfer switch, be sure to cut the film with the manual cut switch. Subsequent operations may malfunction. Also, be sure to pull out the cut film (paper) horizontally from the ejection port with both hands.

## 3. Machine installation



### 3-1. Install the machine

In order to operate the machine smoothly and replace the film smoothly, secure a sufficient space (20 cm or more) around the machine and install it.

※ For the installation environment, please read the warning (about the installation location) and warning (about the power supply and ground) carefully and install correctly.

※ Please contact your dealer or maintenance company for installation and adjustment of this machine.

### 3-2. Set the feeder tray

While pushing down the outside of the feeder tray as shown in the figure on the left, set it as shown in the figure below.

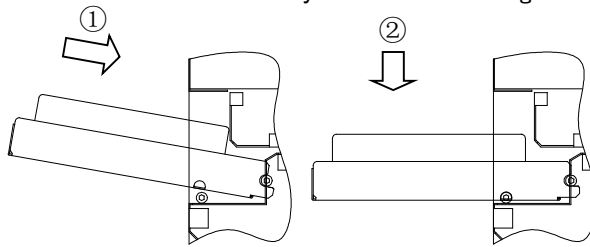

※ When using A3 size, set the expansion tray.

### 3-3. Set the stacker

Insert the tip of the stacker firmly into the stacker mounting hole on the right side of the main unit. Select the mounting hole according to the film thickness you are using.

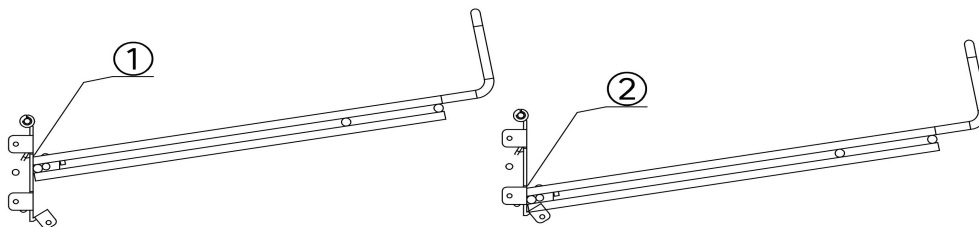

① When using 38mic film

② When using 75mic / 100mic film

### 3-4. Set the trash can

Set the trash can in the stand. Set the trash can on the discharge side.

### 3-5. Set the power cable

Insert the power cable firmly into the lower power socket on the right side of the main unit.

## 4. Film set

1. Prepare the following items.

• **HKK** exclusive film

\* Please prepare the HKK exclusive film "AL-ROLL FILM" sold separately.

\* Because the special film is a set of two, be sure to use it as a set.

· A3 size thick paper (thickness: 0.20 to 0.25 mm)··· 1 sheet

\* At the time of purchase, it is set in this unit.

\* Do not use thick paper smaller than A3 size

· Double-sided tape

· Scissors or **cutter**

2. Open the film cover, feeder cover, and slitter cover in this order.



Notice

⊙ Please note that the temperature inside the machine may be very high.

3. Loosen the tension knob (top) and set the film on the core holder (top) (= roller fixing part).

⊙ the upper part of the clamp in the picture of ④, forward and open it as shown in the picture of ③

⊙ After fitting the left side hole ① of the end of the film roller (film fixing base) and the right side hole ② of the roller fixing part, Tighten the clamp.



Notice

⊙ At this time, set the film without cap on the upper shaft core holder (roller fixing part).

⊙ The special film has a set direction. Please note that setting it in the opposite direction may cause a malfunction.

4. Loosen the tension knob (bottom) and set the film on the core holder (bottom) (= roller fixing part)

⊙ Pull the part on the clamp in the picture of ④ forward and open it as shown in ③

⊙ Set the clamp in the left hole ① of the end of the film roller (film fixing base) and the right hole ② of the roller fixing part and tighten.

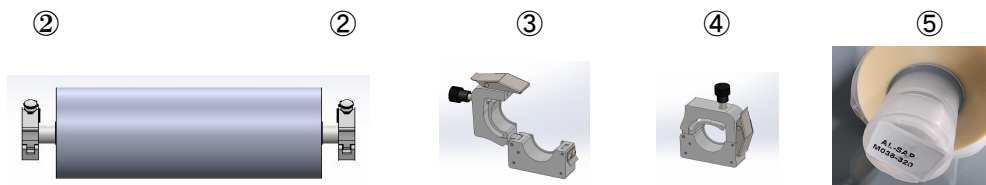

Notice

⊙ At this time, set the film with the cap on the lower shaft core holder (roller fixing part) with the left side.

⊙ The special film has a set direction. Please note that setting it in the opposite direction may cause a malfunction.。

5. Turn the roll-up lever in the direction of the arrow to the OPEN position.

There will be a gap between the heat rolls.

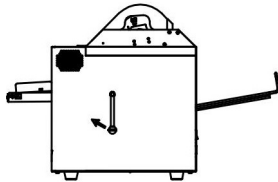

6. Remove the slit adjustment knob from the groove by tilting it toward you, and move it to the film set position (arrow in the picture ).

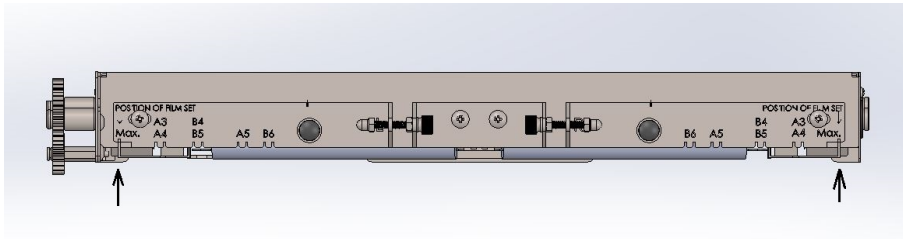

Notice

Ⓢ Doing the film set at a position other than the film set position may cause a malfunction.

7. Plug the power plug into the outlet and turn the power switch ON (I).

8. Insert A3 size cardboard straight until it hits the front roll of the slit unit.

\* Do not use thick paper smaller than A3 size.

Ⓢ Insert the thick paper so that it is located at the center between the side plates (center of the machine).

If it is biased to the left or right side, the cutter unit or slit unit may be damaged

9. Open the upper cover of the slit, check that the thick paper is inserted to the position of the front roll, and check the upper part of the slit. Close the bar.



Notice

Ⓢ The manual transfer switch will not work unless the upper cover of the slit is closed.

10. Press the manual transport switch to transport the thick paper until it is slightly out of the outlet.

11. Turn the roll-up lever in the direction of the arrow to the LAMINATE position. Wait for a while until the machine completes warm-up.

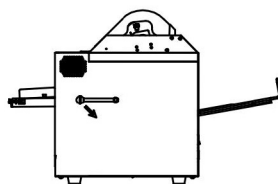

12. Pull out the tips of the upper and lower set films by about 30 cm.



Notice

Ⓢ When purchasing the film, the film is stopped with black tape.

Be sure to remove this black tape. It may cause entanglement or malfunction.

13. Using double-sided tape, attach the upper and lower films to the thick paper.

※ When purchasing the film, double-sided tape is attached to the film.

 Notice

- ◎ Attach the upper and lower films to thick paper so that there are no wrinkles.
- ◎ Paste the upper and lower films so that they overlap.
- ◎ Please note that the temperature around the heat roll may be very high.
- ◎ Attach the double-sided tape so that it does not stick out of the film.
- ◎ Do not set the film using the black tape that holds the film. It may cause entanglement or malfunction.

14. Rewind and adjust the upper and lower films.

15. Tighten the tension knob both up and down to convey the ejected film until there are no wrinkles or air bubbles.

※When loosening, loosen evenly on the left and right.

 Notice

- ◎Be careful that the ejected film does not interfere with the stacker.

16. Transport a little from the film with no wrinkles or bubbles. Place the film about 2 cm from the outlet . Or cut with a cutter.

17. Check the curl (warp) of the cut film.

- ◎ If there is curl (warp) on the film, it may cause trouble. Must check the curl of film before laminating.

 注意

- ◎ If you start the laminating process with the curl without checking the curl and making the following adjustments, it may cause entanglement or malfunction.
- ◎ Be sure to check and adjust the curl before starting the laminating process.

18. Press the manual cut switch to cut the film.

- ◎ The cut film is slowly pulled out horizontally from the outlet with both hands without using the manual transfer switch.

19. Close the feeder cover and then the film cover.

## 5. Operation procedure

### 5-1. Turn on the power and start warming up



Plug the power plug into the outlet.

Turn on (I) the power switch on the upper side of the power socket.

The buzzer beeps and the LCD display shows the initial screen for 3 seconds.

Finally, the warm-up screen is displayed.  
The POWER lamp lights up.

### 5-2. Load the paper

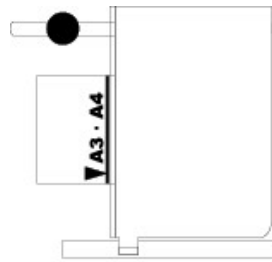

A3•A4paper

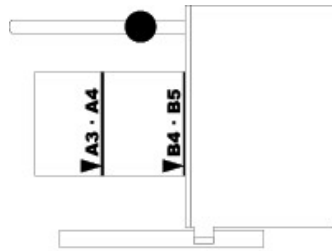

B4•B5 paper

Move the Paper Guy (left and right) in the input tray so that the paper is in the center of the tray. (Loosen the paper guide adjustment knob before moving it.) Tighten the knob after adjustment.



Push down on the edge of the feeder tray by hand.

Set the paper so that it hits the back of the feeder tray (maximum load capacity: 200 sheets of copy paper).

Release the hand holding the end of the feeder tray.

### 5-3. Start / stop laminating



Notice

◎Make sure that the roll-up lever is down.

Make sure that the temperature, speed, margins, fine mode, etc. are set correctly and that the READY lamp is lit.



Press the START button to start laminating.



If you press the STOP button during laminating, laminating will stop.

\* All the paper being laminated will be ejected and stopped.

When processing using the set count, the laminating process will stop when the set number of sheets for the laminating process is completed.

When the film runs out, "Film Shuryo" is displayed and the laminating process is completed.

## 5. Operation procedure

---

## Supplement Eco mode

If the laminating process is not performed for 30 minutes or more, or if the button on the operation panel is not pressed, the eco mode is entered and the temperature is set to 60 ° C.

Press any of the RESET buttons to cancel the eco mode.

\* The buzzer beeps one minute before entering the eco mode.

## 5-4. Finish

1. Please finish the laminating process.
2. Raise the roll-up lever to prevent the heat roll from deforming.
3. Turn off the power switch (○) and check that the LCD display is off.
4. Unplug the power plug.

# 6. Various setting methods

---

## 6-1. Set the temperature

*It is used when you want to change the temperature.*

When you press the [SET] button on the operation panel, the screen for setting the temperature is displayed.

Press the ▲ ▼ button to set the temperature.

The set temperature changes by 5 ° C.

When you change the temperature, the temperature display on the screen flashes. Press the [SET] button again to confirm.

Press the [Menu / Back] button to return to the original screen.

## 6-2. Set the speed

*Use this when you want to change the speed.*

When you press the [SET] button on the operation panel, the screen for setting the speed is displayed.

Press the [▲][▼] buttons to set the speed.

The speed changes by 0.1m / min.

When you change the speed, the speed display on the screen flashes.

Press the [SET] button to confirm. Press the [Menu / Back] button to return to the original screen.

## 6-3. Set count

*It is used to set the number of sheets to be processed.*

Press the [SET] button to display the mode screen.

Press the [▲][▼] button and then press the [SET] button again.

Press the [▲][▼] buttons to switch the display, so set the number you want to laminate.

The set of sheets is free to 200 sheets. Free ⇔ 1 ⇔ 2 ⇔ ... ⇔ 199 ⇔ 200

Press the [SET] button to confirm. Press the [Menu / Back] button to return to the original screen.

If set to Free, the LCD display will show Free. In this case, laminate until the paper loaded in the feeder runs out.

\* The initial value is set to free.

## 6-4. Set with / without margin (border) ... Slitter part

It is used to set the margin (border) of the slitter part.

Move the slitter adjustment knob to set.

–How to move the slitter adjustment knob–

Turn down the slitter adjustment knob to remove it from the groove. Close the slitter cover when the setting is completed.

## 6-5. Margin correction

It is used to change the width of the margin (edge) of the cutter part.

Press the [SET] button to display the mode screen.

Press the [▲][▼] button to move 「>」 to the item you want to set,

and then press the [SET] button again. Press the [▲][▼] buttons to change the set value.

Press the [SET] button to confirm. Press the [Menu / Back] button to return to the original screen.

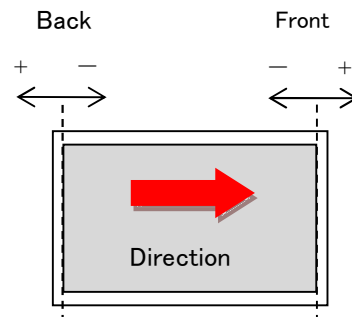

## 6-6. Adjust the paper skew

Use when the paper is skewed.



If necessary, adjust the paper feed skew with the fine adjustment knob on the feeder tray.  
When the finish of the work piece is (A), loosen the fine adjustment knob. When the finished product is (B), tighten the fine adjustment knob.



Notice

©When adjusting the skew, please push down the tray once.

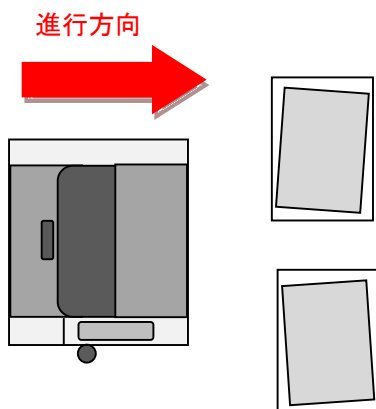

(A) The back side is in front

(B) The operation panel side is in front.

## 6-7. Adjust the position of the paper

Use when the paper is squeezed by either side.

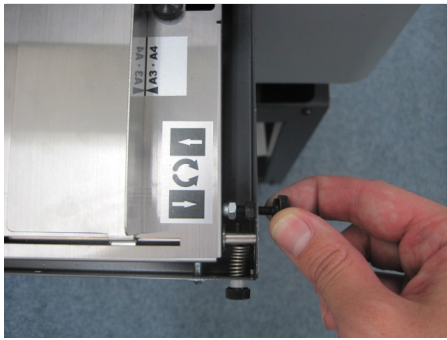

Direction

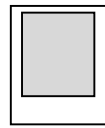
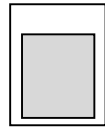
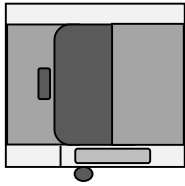

If necessary, adjust the position of the paper with the feed fine adjustment knob on the feeder tray.

When the finished product is (A), turn the feed fine adjustment knob to the right.

When the finished product is (B), turn the feed fine adjustment screw counterclockwise.

(A) Closer to the operation panel side

(B) It is closer to the back side.

## 7. When in trouble

Phenomenon	Checklist	Treatment
<p>● Laminated paper is not ejected (Hansou error) (Laminate error)</p>	<p>Check if Laminate part, cutter part, pickpocket Laminating process near the tatter part where the paper inside is not jammed</p>	<p>[1]Open the "feeder cover" and cut the upper and lower films near the "guide roll". Then, set the "roll-up lever" to the OPEN position. Grasp the paper firmly and pull the film or laminated paper from the insertion side.Please pull it out and press the [RESET] button. If the laminated paper cannot be removed or the error is not cleared, turn off the power (○). Contact the maintenance company or dealer please.</p> <p>[2] Make sure that the slitter unit is free of dust (cutting debris)..</p> <p>[3] Garbage (cut waste) may have accumulated while falling into the trash can. Turn the switch OFF (○) and remove dust (cutting waste) so as not to touch the cutter unit (blade).</p> <p>◎ Be careful not to get burned because the laminated part is hot. ◎ Be careful not to pull your hands or clothes into the roll. ◎ Keep your hands away from the cutter unit. ◎ Do not disassemble. ◎ Please be careful not to cut your hands. ◎ Be careful not to damage the heat roll.</p>

## 7. When in trouble



Phenomenon	Checklist	Treatment
<ul style="list-style-type: none"> <li>● Laminated paper is not ejected (Hansou error) (Laminate error)</li> </ul>	Have you checked and adjusted?	<ul style="list-style-type: none"> <li>· Paper curl Make sure the paper is not curled.</li> <li>· Curl of laminated paper Adjust the film tension.</li> <li>· Amount of trash in the trash can When trash is loaded, the trash during processing may not fall into the trash can and the trash may collect in the slitter unit, so please dispose of the trash in the trash can diligently.</li> </ul>
<ul style="list-style-type: none"> <li>● error occurred</li> </ul>		Press the [RESET] button. If the error persists, please contact your maintenance company or retailer. If the error is cleared, pull out the film or laminated paper please. ◎ Keep your hands away from the cutter unit.
<ul style="list-style-type: none"> <li>● Occurrence of Yoshi error (FEEDING ERROR)</li> </ul>	<ul style="list-style-type: none"> <li>• Did you do Double feed (transport 2 or more sheets)?</li> <li>• Paper is transported 10 cm or more?</li> <li>• Paper is thick and the surface is smooth?</li> </ul>	Please remove the paper. Set the paper feed pressure adjustment knob to 1 memory. Please handle the paper firmly. Remove the curl on the paper. Press the [RESET] button.
	<ul style="list-style-type: none"> <li>• Is the paper transported more than 3 cm?</li> <li>• Is the paper too thin?</li> </ul>	Please remove the paper. Set the paper feed pressure adjustment knob one memory down. Please handle the paper firmly. Remove the curl on the paper. Press the [RESET] button.
	Is the paper transported in a large angle	Please remove the paper. Use the "Paper Guide Adjustment Knob" to expand the "Paper Guide" a little. Press the [RESET] button.
	Is the paper feed roll dirty?	Please remove the paper. Open the "feeder cover". Clean the "paper feed roll" from dirt. Press the [RESET] button.
<ul style="list-style-type: none"> <li>● Kamizumari error occurred (PAPER JAM)</li> </ul>	Is the paper jammed between the feeder and the laminator?	Open the "feeder cover". Remove all jammed paper and film. Remove the curl on the paper.  Press the [RESET] button. ◎ Be careful not to get burned because the laminated part is hot.

## 7. When in trouble

Phenomenon	Checklist	Treatment
●Hansou error occurred (FEEDING ERROR)	Is the paper jammed between the cutter and the slitter?	Pull out the film or laminated paper
●Lamination error occurred (LAMINATION ERROR)	Is the paper jammed between the cutter and the laminator?	[1]Pull out the film or laminated paper. [2] If there is paper in the "feeder tray", slowly pull it out toward you. If the error is not cleared, turn off the power (○). Please contact the maintenance company or your dealer.  ⓄBe careful not to get burned because the laminated part is hot. Ⓞ Be careful not to pull your hands or clothes into the roll. Ⓞ Keep your hands away from the cutter unit. Ⓞ Do not disassemble.
	Is the position of the roll operation lever set to OPEN?	[1]Pull out the film or laminated paper. Set the position of the "roll-up lever" to the position of LAMINATE. Press the [RESET] button.
	Is the film finished?	[1]Pull out the film or laminated paper. Remove the film from the unit. Press the [RESET] button. Replace the film. Ⓞ Be careful not to get burned because the laminated part is hot.
	Is the Filmed or laminated paper curved?	Please clear the error. (●Refer to the items to be confirmed and the measures to be taken when a laminating error occurs). Adjust the "tension knob" on the film.
●Yoshinokoriari error occurred (PAPER STUCK CALL FOR SERVICE)	Is there any paper in the process of laminating near the laminating part, cutter part, or slitter part?	Open the "feeder cover" and "slitter cover". Remove all jammed paper that is in the process of being laminated (see: "Laminated paper is not ejected" (P38), and then take the steps in the film or laminating. You can check where it is clogged by looking at the part displayed in red on the LCD display.  Red part of the display 1: Feeder part 2: Laminate cutter part 3: Slitter part Press the [RESET] button.  If the error is not cleared, turn off the power (○). Contact the maintenance company or your dealer.
● Yoshinokoriari error occurred (continued)	Is there any dust (cut scrap)?	Look above the trash can and remove all dust (cutting debris). Press the [RESET] button. Ⓞ Please be careful not to cut your hands.

## 7. When in trouble

Phenomenon	Checklist	Treatment
● Film error occurred (CHECK FILM)	Is the film with IC installed correctly on the underside?	Install the film with IC exactly on the bottom side.
● Cover opened error occurred (COVER OPEN)	Is the cover open?	Close the "feeder cover" and "slitter top cover". Press the [RESET] button.
● Overheat error occurred (OVER HEAT)		Turn off the power (○). Turning the power on (I) will eliminate the error. If it occurs frequently, please contact the maintenance company or your dealer.
● Ondo Sensor Dan Sen error occurred (TEMP SENSOR BREAK)		Turn off the power (○). Please contact the maintenance company or your dealer. ⊙ Please do not disassemble.
● Lami motor error occurred (LAMI MOTOR ERROR)		Turn off the power (○). Please contact the maintenance company or your dealer. ⊙ Please do not disassemble.
● Ondo Sensor Dan Sen position error stop (TEMP SENSOR POSITION)		Turn off the power (○). Turning the power on (I) will eliminate the error. · Pull out the film or laminated paper.
● The slitter is cut Bad (PAPER STUCK) CALL FOR SERVICE	Is there any dust (cut scrap) accumulated in the slitter unit?	Look above the trash can and remove all dust (cutting debris). ⊙ Please be careful not to cut your hands. ⊙ Garbage (cut waste) may have accumulated while it is falling into the trash can. Turn OFF Power switch (○) and remove dust (cutting waste) so as not to touch the cutter unit (blade).
		It may have exceeded its lifes Contact the maintenance company or retailer when. ⊙ Do not disassemble.
● The slitter is cut bad	Is tension knob tighten up?	Tighten the "tension knob"
● Error not mentioned		Turn off the power (○). Please contact the maintenance company or your dealer. ⊙ Do not disassemble.

## 8. Machine specifications

Product name (model number)	HLA-2301
Maximum laminate width	320mm
Maximum laminate thickness	0.4mm(including film thickness)
Corresponding film thickness	38、75、100、125mic(0.038、0.075、0.100、0.125mm)
Corresponding paper thickness	0.07~0.25mm (70~250mic•64~240g/m <sup>2</sup> )
Laminating speed	0.5~1.7m/min
Range of temperature	80~130°C
Warm-up time	About 6mins and a half
Power-supply voltage	AC100~240V(50/60Hz)
Power consumption	1.2kW
Size	1,272(W) x 600(D) x 1,100(H) mm When assembling the stand, feeder tray, expansion tray, and stacker
Weight	Body :47kg Stand:27kg
Feeder tray capacity	200 sheets(copy paper)
Stacker capacity	200 sheets(processing copy paper with 100mic film)
Applicable temperature and altitude	0~30°C(recommended 20±5°C)/2,000m above sea level
Accessories	Feeder tray, expansion tray, stacker, power cable, Instruction manual, warranty card, trash can, stand, stand assembly manual, Tools (for stand assembly), screws (for stand assembly)

※Finishing angle processing is square (right angle).

※The life of the cutter and slitter is 50,000 sheets

※The warm-up time may vary depending on the ambient temperature and set temperature.

## 9. Stand specifications

This Model HLA-2301 is for use only with HLA2301-S by Kalbas Limited.  
Use with other stand may result in instability causing injury.

