

# ***INSTALLATION MANUAL***

---

FOLDER

DUPLO FOLDER

**DF-999/DF-999A**

**DF-990/DF-990A**

***Service Person Only***

# **Duplo**

# 1. Installation Precautions

## 1-1. Before installation

- Check that before the installation, the power switch [A] is turned off.
- Check that the voltage and frequency of the area in which this machine is used match the specifications on the label [B] pasted on the machine.
- When removing the machine from the container, lift the bottom [C] of the machine at two people.

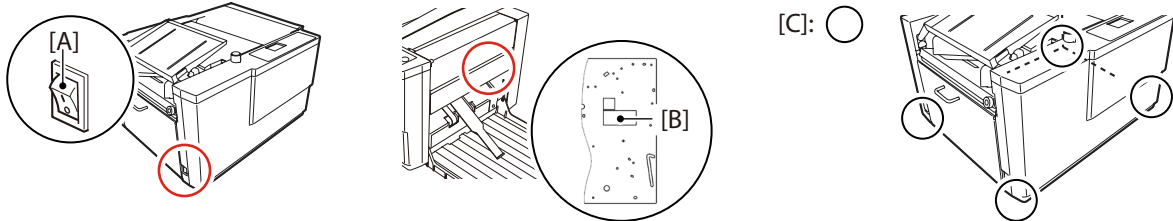

- A machine in the photos shown in this manual is a prototype. The colors and forms of the parts shown in the photos may be different from those of the production model.

## 1-2. Installation location

- Install the machine on strong solid ground which can bear the weight of the machine. The weight of the machine is as follows.

DF-999/DF-999A : 43.0 kg/94.8 lb (This unit: 41.6 kg/91.8 lb, Accessories: 1.0 kg/2.2 lb)

DF-990/DF-990A : 42.0 kg/92.6 lb (This unit: 40.6 kg/89.6 lb, Accessories: 1.0 kg/2.2 lb)

- The following installation space(width x depth x height)is required.

1,112 x 512 x 554 mm/43.78 x 20.16 x 21.82 inches

- Install the machine in a flat and stable place.
- Do not install this machine near a heating equipment such as a stove.
- Install in a place which meets the following requirements.

Temperature range: 5 to 35°C, 41 to 95°F

Humidity range: 20 to 80%RH (No condensation)

No direct sunlight

Outside light does not exceed 1,500 lx

Little dusts and dirt

Little vibrations

No salt

No special chemicals

No exposure to water

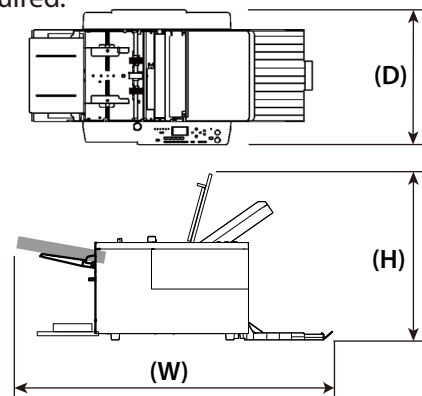

## 1-3. Power supply

- Make sure the power supply used is always within the following range.

**Power supply: 100 to 240 V, 50/60 Hz**

- When you power other appliances from the same wall outlet, make sure that the combined power consumption does not exceed the power supply capacity.

**Rated power: 100 W**

**Rated current: 1.0 A to 0.5 A**

## 2. Accessories

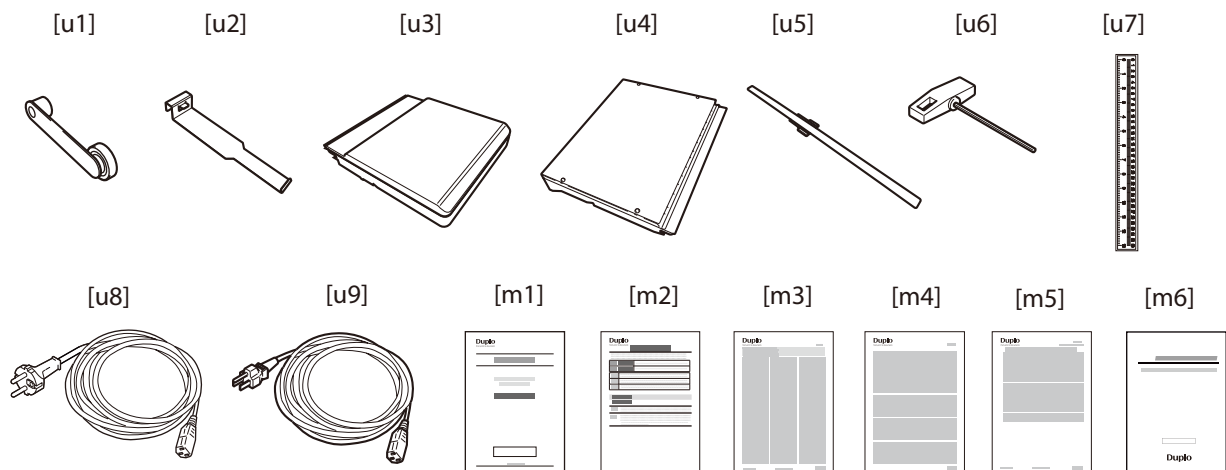

No.	Name	Qty.		Remarks
		DF-999/ DF-999A	DF-990/ DF-990A	
[u1]	Cross fold lever	1	1	
[u2]	Auxiliary paper ejection guide	1	1	
[u3]	Folding plate 1	1	1	
[u4]	Folding plate 2	1	1	
[u5]	Paper support guide	1	1	
[u6]	T-handle hexagonal wrench	1	1	For User (tool)
[u7]	Scale label	1	1	
[u8]	Power cord	1	1	For EU
[u9]	Power cord	1	1	For NA
[m1]	Instruction manual	1	1	
[m2]	Safety Guide A	1	1	
[m3]	DECLARATION OF CONFORMITY	1	1	For EU
[m4]	WEEE Statement	1	1	For EU
[m5]	Statement of Electromagnetic Compatibility (EMC)	1	1	For NA
[m6]	Installation manual	1	1	This manual

## 3. Preparation

The press release lever have been installed to avoid the deformation of the folding roller.  
Be sure to remove the press release lever when installing.

**!** If the folding plate 1 is set before removing the press release lever, the folding plate 1 may become deformed or damaged. Be sure not to turn on the power before removing the press release lever.

### 1 Open the top cover.

[A] Top cover..... 1

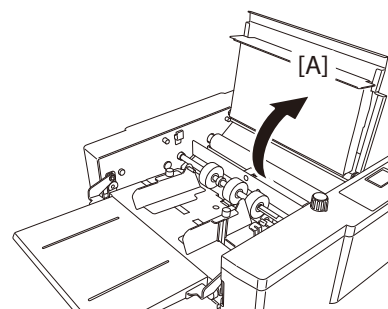

**2 Remove the tapes that secure the press release lever.**

[B] Tape .....2

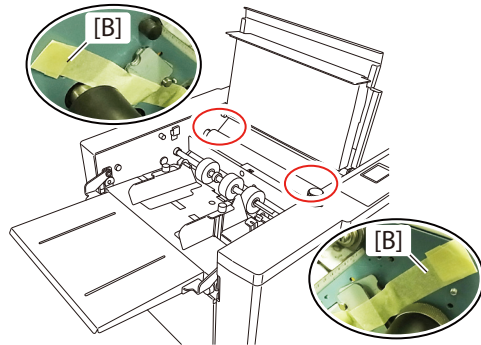

**3 Remove the press release lever 1 in the direction of the arrow.**

[C] Press release lever 1 .....2

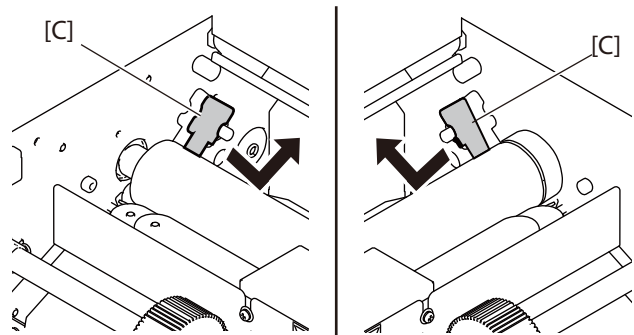

**4 Remove the press release lever 2 in the direction of the arrow with the same as step 3.**

[D] Press release lever 2 .....2

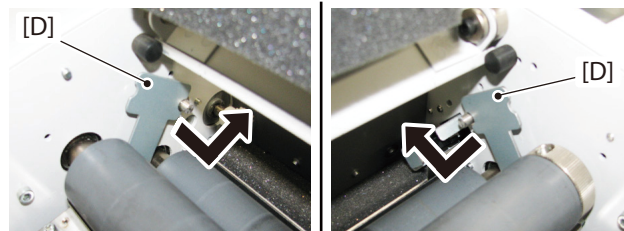

**5 Close the top cover opened in step 1.**

[A] Top cover..... 1

☞ Step 1 of "3. Preparation" (p.3)

## 4. Installation Procedures

📖 Installation procedures of this machine, refer to the instruction manual of this machine.

## 5. Setting Control Panel

📖 For the setting of the language to be displayed, refer to the service manual of this machine.