

Duplo

from print to documents

INSTRUCTION MANUAL

FOLDER
DUPLO FOLDER

DF-999/DF-999A
DF-990/DF-990A

Original instructions

Be sure to read this manual prior to use.
Please leave this manual at the site of use for easy reference.

Introduction

Thank you for purchasing a Duplo product.

Be sure to read this manual and "Safety Guide A" supplied with this product before use. "Safety Guide A" contains information for correct and safe use of this product.

After reading, leave the manual and "Safety Guide A" at the site of use for easy reference whenever questions related to the product arise in the future.

Symbols

In this manual, several symbols are used to indicate important warnings. Please make sure to read instructions accompanied by these symbols. These symbols have the following meanings.



Describes instructions which must be followed in use.

Be sure to read the instructions to avoid problems due to incorrect operations.



Indicates supplementary or useful information.



Describes names of related items and supplementary instructions.

Trademark

The product name and company name used in this manual are trademarks or registered trademarks of the respective companies.

Copyrights

Reproduction or reprinting of this document in part or in whole without permission is prohibited.

Safety Precautions

Power supply

- Make sure the power supply used is always within the following range.
Power supply : 100 to 240 V AC, 50/60 Hz
- When you power other appliances from the same AC outlet, make sure that the combined power consumption does not exceed the power supply capacity.
Rated power: 100 W
Rated current: 1.0 to 0.5 A

Operating environment

Operate this unit in the following environment.

- where the temperature range is between 5 and 35°C/41 and 95°F (-10 to 50°C/14 to 122°F in storage)
- where the humidity range is between 20 and 80% RH (10 to 90% RH in storage, however no condensation)
- which is not subject to direct sunlight
- where the outside light does not exceed 1,500 lx
- which is subject to little or no vibration
- where the unit is kept away from air-borne salt
- where the unit is kept away from harmful chemicals
- where the unit is not exposed to water

WARNING/CAUTION labels

- ▼ **"WARNING" and "CAUTION" labels are pasted on the machine to ensure user safety.**
Do not remove or change them.
When the labels become dirty or are lost, be sure to contact your dealer for a new one.

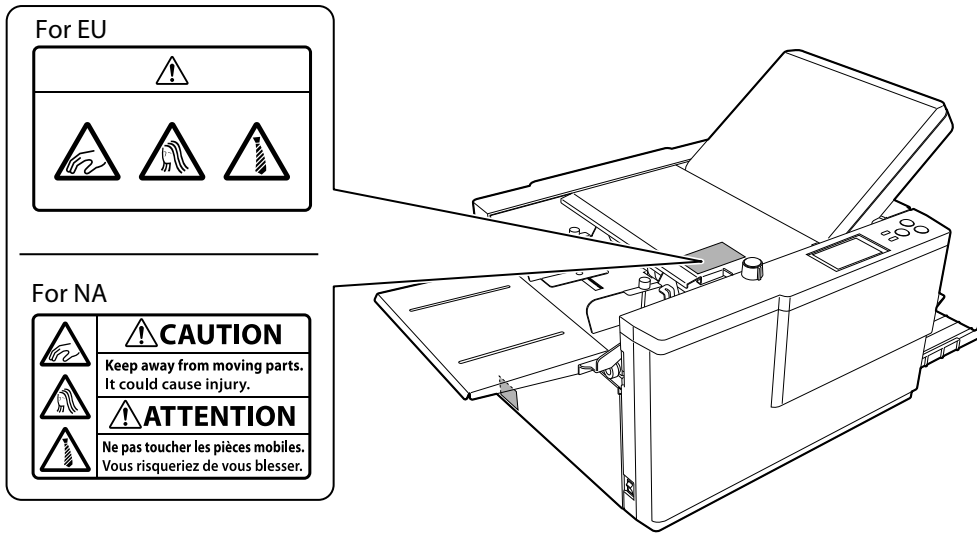

When DF HAND FEED KIT (option) is attached:

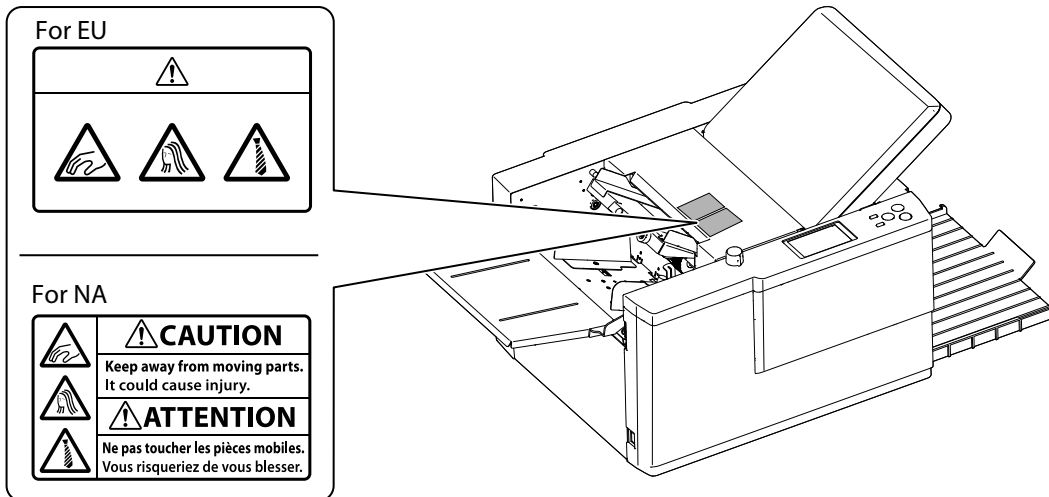

Contents

Safety Precautions	i
Power supply	i
Operating environment	i
WARNING/CAUTION labels	ii

Chapter 1 Before Operation

1. Features	3
2. Setting Up the Machine	3
2-1. Before installation	3
2-2. Accessories	4
2-3. Installation procedures	5
2-4. Connecting power cord	8
2-5. Checking operations	8
3. Names and Functions of Components	8
3-1. External parts	8
3-2. Internal parts (Paper ejecting section)	9
3-3. Internal parts (Top cover section)	10
3-4. DF HAND FEED KIT (Option)	11
4. Names of Control Panel	11
5. LCD Touch Panel	12
6. Screen Configuration	13
6-1. [Ready] screen/[Processing] screen	13
6-2. [Basic Settings] screen	18
6-3. [Standard Size] select screen	18
6-4. [Folding Mode] select screen	19
6-5. [Paper Length] input screen	20
6-6. [No. of Sheet] input screen	20
6-7. [Fold Position] screen	21
6-8. [Stacker Roller] screen	22
6-9. [Custom Fold] screen	23
6-10. Folding A/Folding B input screen	26
6-11. [Function Settings] screen	27
6-12. Classification of buzzer sounds	29
7. Paper Types and Sizes	29
Paper that cannot be used with this machine	29
8. Handling Paper	30
8-1. Paper used	30
8-2. Precautions on stacking paper	30
9. Options	31
DF HAND FEED KIT	31
10. Workflow	32

Chapter 2 Basic Operation

1. Turning On/Off the Power	33
1-1. Turning on power	33
1-2. Turning off power	33
2. Stacking the Paper	34
2-1. Before stacking paper	34
2-2. Stacking paper	34
3. Standard Folding of Standard Paper	36
4. Storage of Machine	41

Chapter 3 Advanced Operation

1. Correcting Folding Misalignment	42
1-1. Adjustment folding misalignment in right and left direction	42
1-2. Adjustment folding misalignment in up and down direction	43
1-3. Deformed folding	46
2. Standard Folding of Non-Standard Paper	46
3. Custom Folding	47
3-1. Operation	47
3-2. Editing saved data	49
3-3. Using saved data	49
3-4. Locking saved data	50
3-5. Deleting saved data	50
3-6. Directly saving folding value under processing	50
4. Cross Fold	51
4-1. Cross fold of standard paper	51
4-2. Cross fold of non-standard paper	55
4-3. Cross fold paper at desired folding position	56
5. Using Special Paper	56
5-1. Art paper, coated paper	56
5-2. Rough paper, recycled paper	57
5-3. B7, A7, A6 size paper (For EU)	58
6. Stacker Roller	58
6-1. Changing stacker roller height	58
6-2. Adjusting stacker roller position	59
7. Stacking the Folded Paper	60
8. Function Setting	61
8-1. Thick paper mode	61

8-2.	Thin paper mode	61
8-3.	Interval function	61
8-4.	Double-feed detection.....	63
8-5.	Detection	65
8-6.	Initial	65
8-7.	Initial screen.....	67
8-8.	Custom screen	68
8-9.	Idling.....	69
8-10.	Tone.....	70
8-11.	mm/inch.....	70
8-12.	LCD bright	71
8-13.	Number of test sheets	72
8-14.	Language.....	72
8-15.	Power saving	73
8-16.	Alarm (DF-999/DF-999A).....	74

Chapter 4 Using the DF HAND FEED KIT

1.	Applicable Paper and Folding Mode	75
1-1.	Paper to be used	75
1-2.	Folding modes.....	75
2.	Staples	76
2-1.	Usable staplers.....	76
2-2.	Usable staples	76
2-3.	Stitching with stapler	76
3.	Manual Feed Mode Setting	77
4.	Operation	78
5.	Correcting Folding Misalignment.....	79
5-1.	Adjustment folding misalignment in up and down direction	79
5-2.	Adjustment folding misalignment in right and left direction	80
5-3.	Abnormal folding	80

Chapter 5 Cleaning the Machine

1.	Cleaning paper feed rings and folding rollers.....	81
2.	Cleaning sensor.....	82
3.	Cleaning LCD touch panel	83
4.	Cleaning stacker belt	83
5.	Cleaning paper separator	83

Chapter 6 Trouble Guide

1.	Error Code	84
1-1.	Warning error	84
1-2.	Motor error	85
1-3.	Paper jam error	86
1-4.	Other errors.....	86
1-5.	Errors requiring a service call.....	87
2.	Paper Jam	87
2-1.	Paper feed ring	87
2-2.	Folding roller	88
2-3.	Folding plate.....	88
2-4.	Ejecting section.....	89
3.	Troubleshooting	90

Chapter 7 Appendix

1.	Specifications.....	93
-----------	----------------------------	-----------

Chapter 1 Before Operation

1. Features

- This machine is designed to fold paper into six popular folding modes.

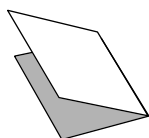

Single fold

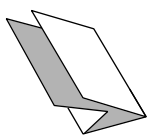

Double fold

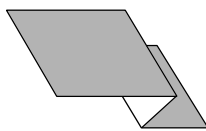

Irregular
accordion fold-out

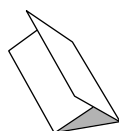

Letter fold

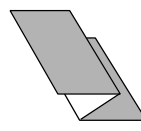

Accordion-fold

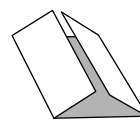

Gate fold

- Use the cross fold lever to fold single folded paper further into standard folding.
- Use the DF HAND FEED KIT (option) to bind and fold at maximum three sheets of paper simultaneously.

2. Setting Up the Machine

2-1. Before installation

- Do not fall down the folding plates. Make sure the folding plates are not subject to shock. Otherwise, the folding plates may damage, resulting in poor folding accuracy.
- The machine may make loud sounds while operating according to the processing speed and paper used due to its paper-folding mechanism.
- Be sure to move this machine with the bottom surface of this machine held by two persons.

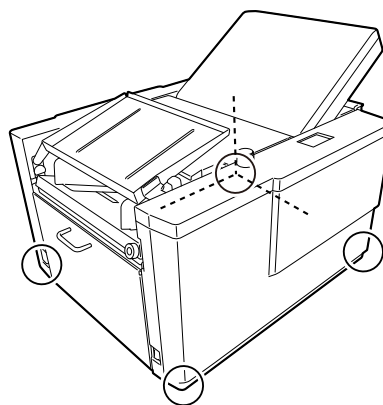

2-2. Accessories

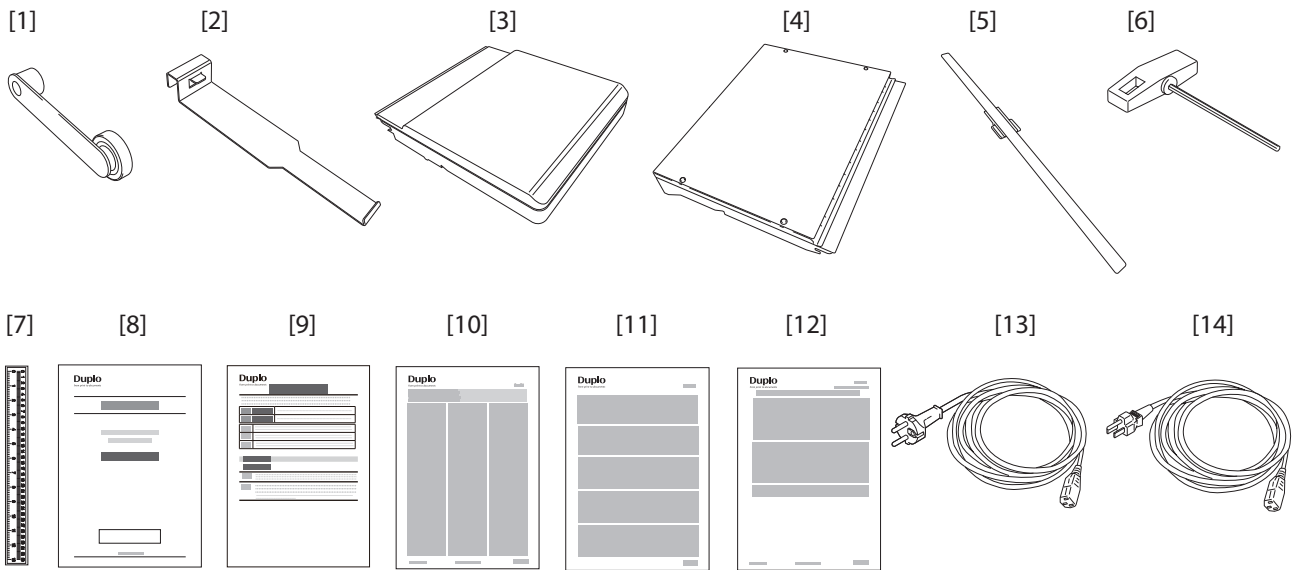

No.	Name	QTY		Function
		DF-999/ DF-999A	DF-990/ DF-990A	
[1]	Cross fold lever	1	1	For holding down the folded paper when cross fold.
[2]	Auxiliary paper ejection guide	1	1	Attached to the stacker roller at the ejecting section.
[3]	Folding plate 1	1	1	Attached to the upper right section on the operator's side.
[4]	Folding plate 2	1	1	Attached to the lower left section on the operator's side.
[5]	Paper support guide	1	1	Attach it to the paper receiving tray from the paper ejecting section. A4/LT size fine quality paper of 64 g/m ² /43.52 lbs, 81.4 g/m ² /55.35 lbs will be well in alignment by using this paper support guide at the time of paper ejection for letter fold or accordion fold.
[6]	T-handle hexagonal wrench	1	1	Used when moving the auxiliary paper feed ring. Do not use the T-handle hexagonal wrench for a purpose other than handling the auxiliary paper feed ring as instructed in this manual.
[7]	Scale label	1	1	Used to measure non-standard size paper. Attach the scale.
[8]	Instruction manual	1	1	This manual
[9]	Safety Guide A	1	1	Contains information for correct and safe use of this machine.
[10]	DECLARATION OF CONFORMITY	1	1	For EU
[11]	WEEE Statement	1	1	For EU
[12]	Statement of Electromagnetic Compatibility (EMC)	1	1	For NA
[13]	Power cord	1	1	For EU
[14]	Power cord	1	1	For NA

2-3. Installation procedures

1 Open the side cover.

2 Remove the tape fixing the lever.

! Be sure to remove the tape fixing the lever.
If you use the machine without removing the tape, the machine cannot detect the presence of the folding plate 2.

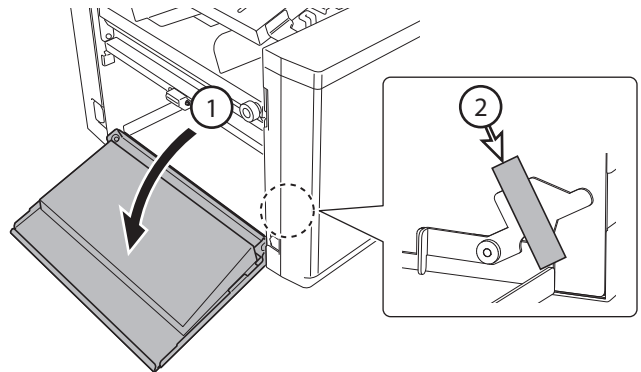

3 Check that the folding stopper does not protrude from the cover on the paper feeding side of the folding plate 2.

When attaching the folding stopper to this machine with the folding stopper protruding from the cover, the folding stopper will touch inside the machine. If so, rotate the gear in the direction of an arrow to move the folding stopper to the inner section of the cover.

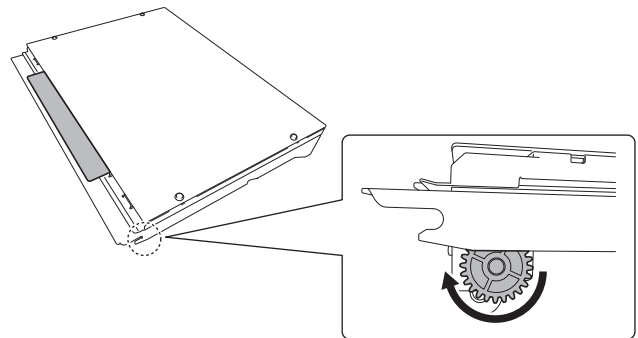

! Do not hold the belt section of the folding plate 2. Doing so will result in malfunction of the machine.

4 Hold the folding plate 2 as shown in the figure, and insert it into the machine.

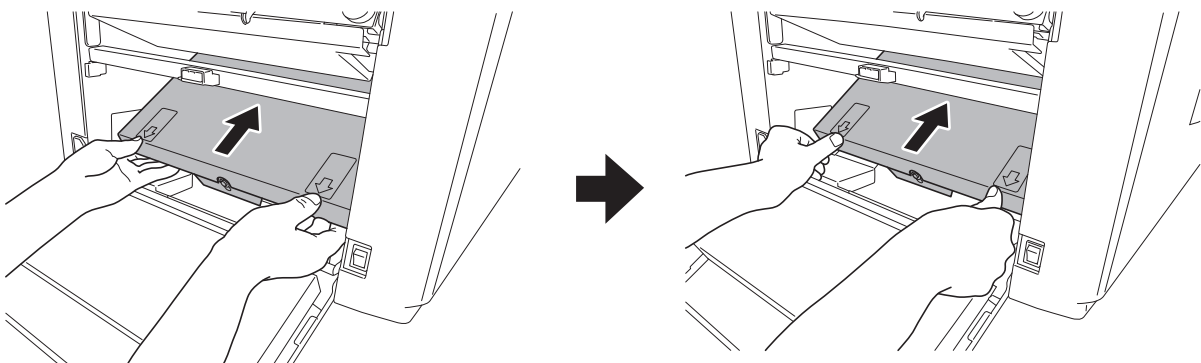

Hold the areas that are indicated with the labels on the folding plate 2.

Insert the folding plate 2 with its rollers [A] moving along the rails [B] of the machine.

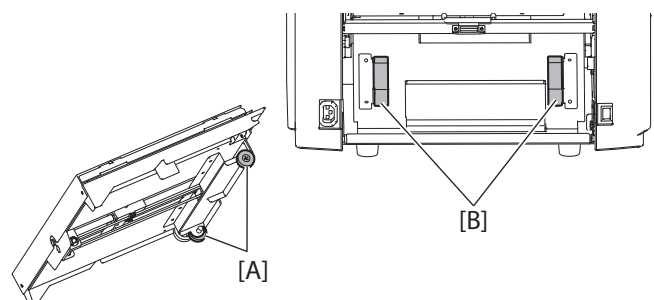

Be sure to check that the folding plate 2 is attached properly as shown in the right figure.

- **Attach the folding plate 2 holding with both hands.**
- **The side cover will not be closed, if the folding plate 2 is not attached correctly. Do not close the side cover forcibly, when the side cover is not closed. Breakage may be caused by doing so.**

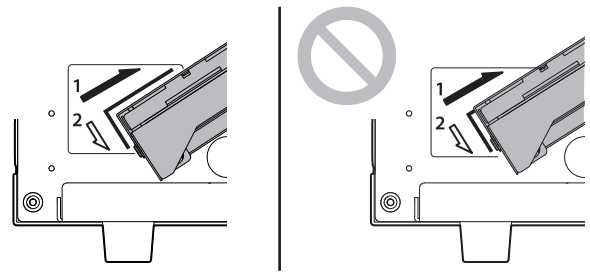

5 Store the T-shape hexagonal wrench, accessory part, at the position inside the machine as shown in the figure.

6 Close the side cover.

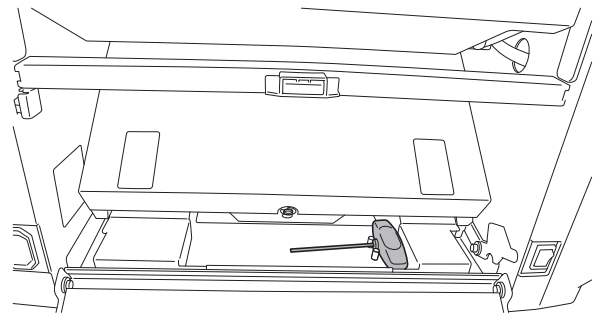

7 Open the support paper feed tray to the left side from the operator's view point.

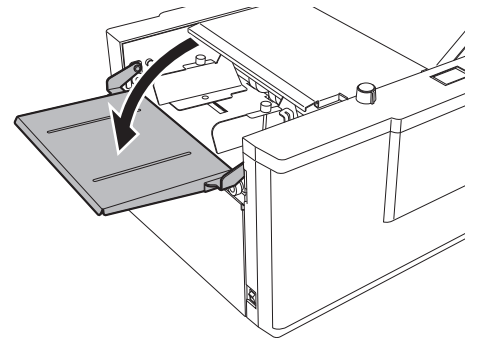

8 Insert the folding plate 1 into the main body of the machine along with the set guide.

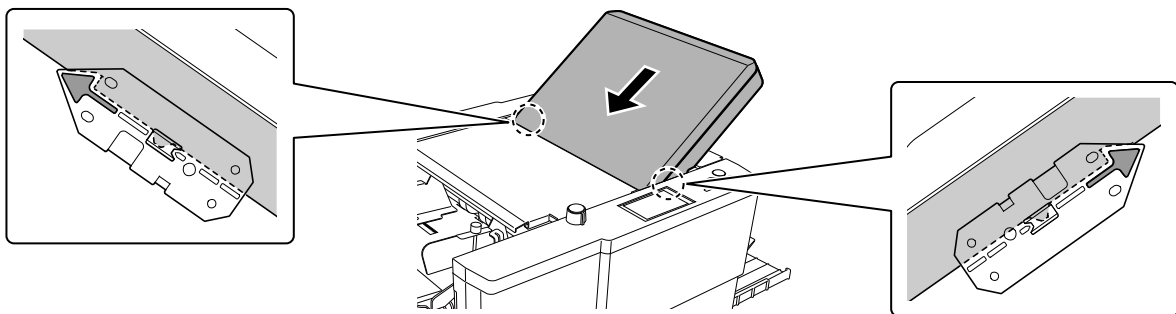

▼ **Attach the folding plate 1 holding with both hands.**



Check that the gear on the reverse side of the folding plate 1 rotates in the front-back direction, if it is not easy to attach the folding plate 1.

Attach the folding plate 1 to this machine after rotating the gear by 360 degree in a rotating direction, when it does not rotate either in the front direction or in the back direction.

9 Open the top cover.

! WARNING	
!	<p>Open or close the top cover gently. Hands or fingers may be caught in the cover section. Doing so may result in injury.</p>

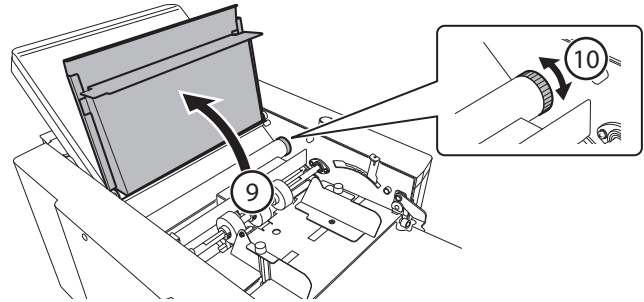

10 Rotate the jam correction handle to check that the folding roller rotates smoothly.

11 Place the cross fold lever as shown in the figure.

! Be sure to store the cross fold lever at the specified place and in the specified direction. By moving during operation of this machine the folding roller may be damaged, resulting in malfunction.

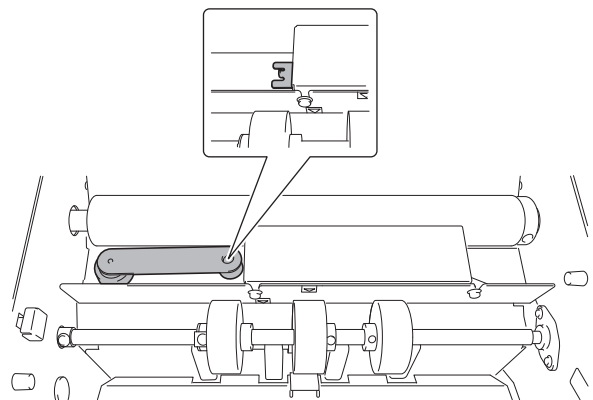

12 Close the top cover.

13 Open the paper receiving tray to the right side seen on the operator's side.

14 Attach the auxiliary paper ejection guide to the stacker roller.

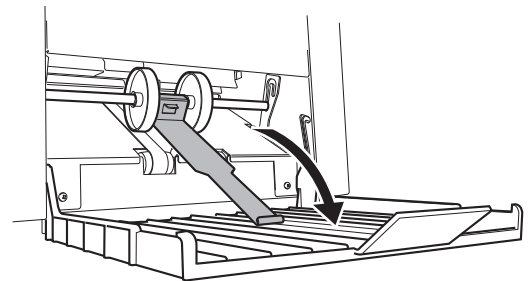

2-4. Connecting power cord

1 Install the power cord to the machine.

⚠ WARNING	
	Do not touch the power plug with wet hands. Otherwise electric hazards may occur.

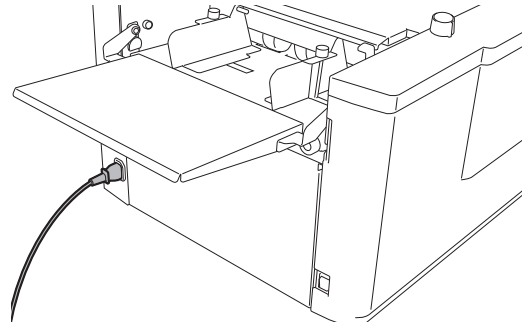

2 Connect the power plug to the outlet.

2-5. Checking operations

- Use the paper to be used actually when checking operations.
- The folding position may be subtly different when using the machine with the settings at the shipment unchanged under the influence of the thickness and stiffness of paper to be used. The folding position may also be subtly different as the characteristics of paper may vary depending on the purchase season even if the paper of the same size is purchased.

For checking operations, refer to “Chapter 2 Basic Operation” (p.33).

3. Names and Functions of Components

3-1. External parts

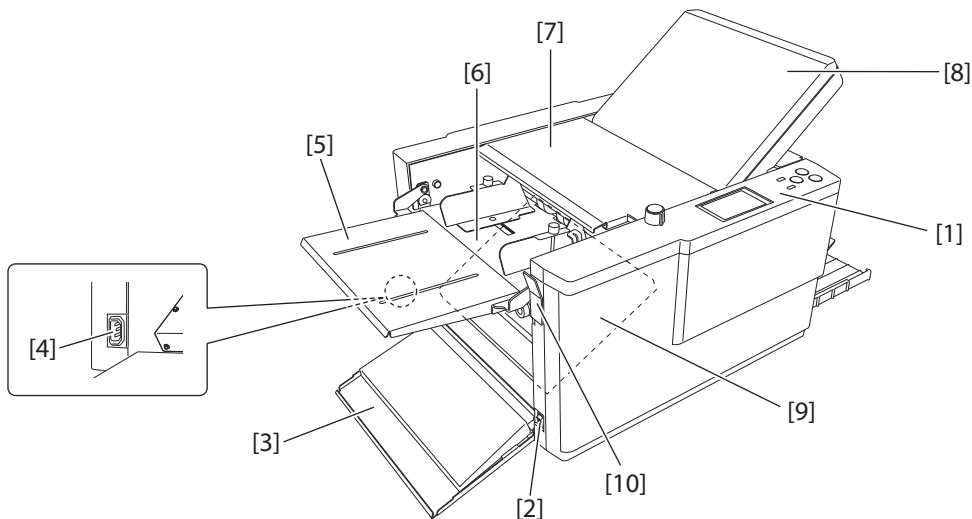

No.	Name	Function
[1]	Control panel	Use this panel to enter information to operate the machine.
[2]	Power switch	 Chapter 2 “1. Turning On/Off the Power” (p.33)

No.	Name	Function
[3]	Side cover	Safety cover to prevent the user from touching the moving parts.
[4]	Power inlet	Connector for the power cord.
[5]	Support paper feed tray	For ensuring paper are stacked on the paper feed tray properly.
[6]	Paper feed tray	For stacking the paper to be folded.
[7]	Top cover	Safety cover to prevent the user from touching the moving parts. The top cover keeps hands or fingers from being caught and injured by braking the opening or closing motion.
[8]	Folding plate 1	Guide plate for deciding the paper folding position.
[9]	Folding plate 2	
[10]	Paper set lever (DF-990/DF-990A)	This lever is used to move the paper feed tray up and down when stacking paper.

3-2. Internal parts (Paper ejecting section)

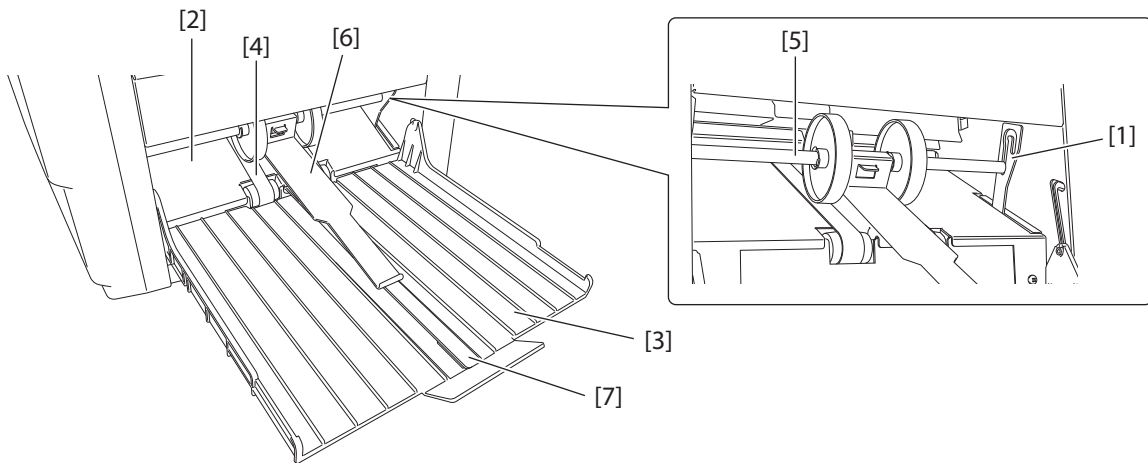

No.	Name	Function
[1]	Stacker lever	This is the lever that supports the stacker roller. The height of the roller can be adjusted.
[2]	Ejecting section	For receiving folded paper ejected out.
[3]	Paper receiving tray	For stacking ejected paper.
[4]	Stacker belt	For ejecting folded paper.
[5]	Stacker roller	It holds down the ejected paper and supports conveyance of paper.
[6]	Auxiliary paper ejection guide	Used to hold the ejected paper.
[7]	Paper support guide	A4/LT size fine quality paper of 64 g/m ² /43.52 lbs, 81.4 g/m ² /55.35 lbs will be well in alignment by using this paper support guide at the time of paper ejection for letter fold or accordion fold.

3-3. Internal parts (Top cover section)

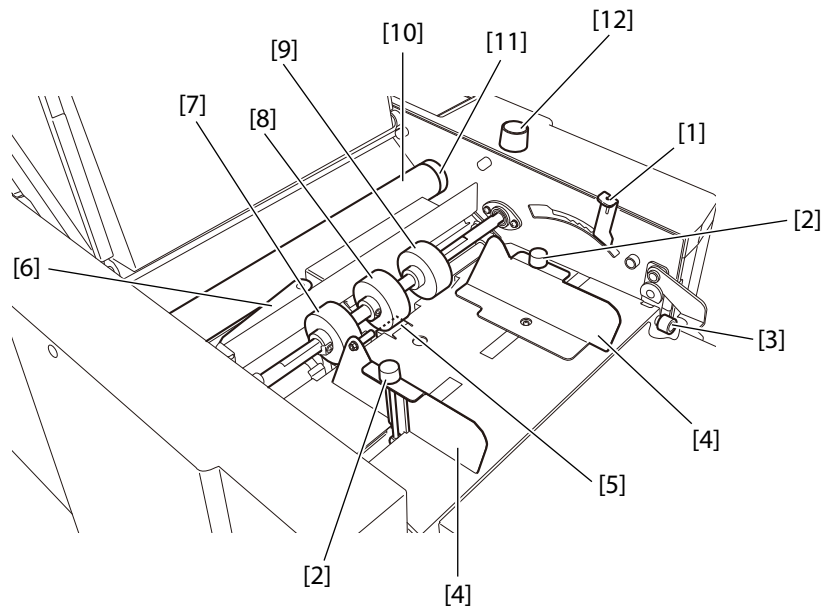

No.	Name	Function
[1]	Feeding pressure adjustment lever	For adjustment the paper feed pressure.
[2]	Guide fixing screw	For securing the paper feed guide.
[3]	Skew correction knob	For correcting skewed paper feed.
[4]	Paper feed guide	For holding paper stacked on the paper feed tray firmly.
[5]	Paper separator	Located underneath the paper feed ring, and prevents double-feed (feeding of multiple sheets of paper at a time).
[6]	Cross fold lever	For holding down the folded paper when cross fold.
[7]	Auxiliary paper feed ring (movable)	Functions in the same way as the auxiliary paper feed ring. The position can be adjusted in accordance with paper size in cross fold.
[8]	Paper feed ring	The main paper feed ring. Ensures smooth feeding of paper in combination with the paper separator.
[9]	Auxiliary paper feed ring	For holding down curled paper for reliable paper feed.
[10]	Folding roller	These rollers are used to fold paper. This machine is equipped with four rollers to make six types of folding.
[11]	Jam correction knob	For rotating the folding rollers when paper has jammed inside the machine or when cleaning the machine.
[12]	Separating pressure adjustment dial	For adjustment the paper separating pressure.

3-4. DF HAND FEED KIT (Option)

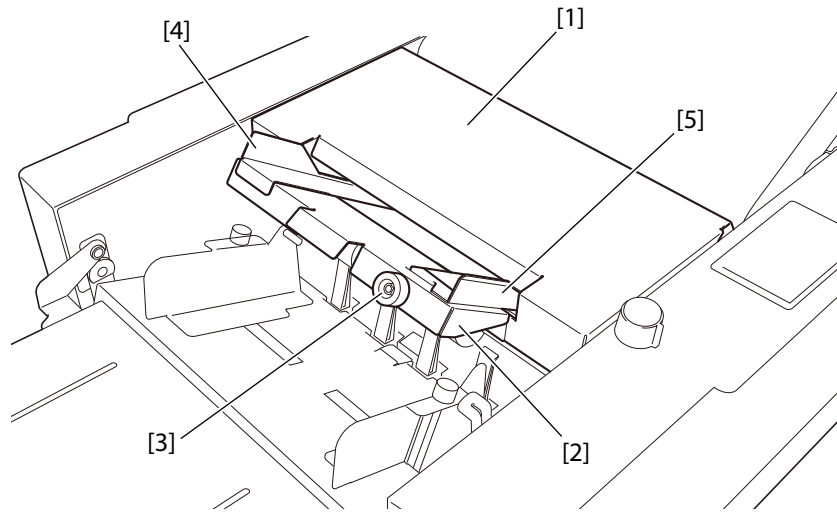



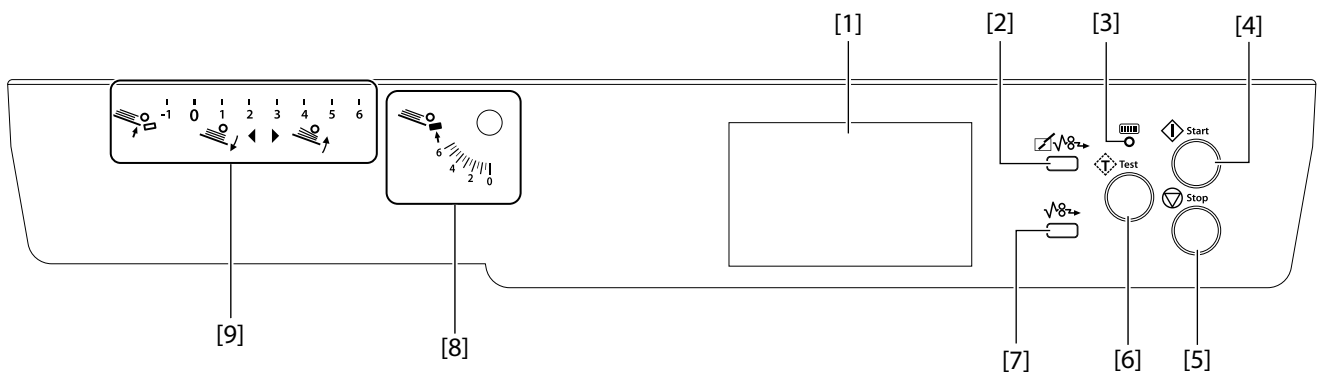

No.	Name	Function
[1]	Manual feed top cover	Safety cover to prevent the user from touching the moving parts. The top cover keeps hands or fingers from being caught and injured by braking the opening or closing motion.
[2]	Manual paper feed tray	Stack paper to be fed manually and folded.
[3]	Manual skew correction knob	For correcting skewed paper feed.
[4]	Auxiliary feed guide	Subordinately guides sheets so that the paper will be fed properly. (magnet type).
[5]	Manual feed guide	Guides sheets so that the paper will be fed properly.

4. Names of Control Panel



No.	Name	Function
[1]	LCD touch panel	Menu and error messages are displayed. Touch to operate.
[2]	↗↘ (folding plate paper ejection) key	Press and hold to forcibly eject paper from inside the folding plate.

No.	Name	Function
[3]	Lamp	When the machine is in the power saving mode, the lamp blinks slowly. When a message requiring service personnel is displayed, the lamp blinks faster.
[4]	 (start) key	Press to start paper folding.
[5]	 (stop) key	Press to stop paper folding.
[6]	 (test) key	Press to test fold. By testing the paper feed, the machine will remember the thickness of the paper.
[7]	 (paper ejection) key	Press and hold to forcibly eject paper from inside the machine.
[8]	Separating pressure adjustment scale	This scale is used when adjusting the separating pressure.
[9]	Paper feed pressure adjustment scale	This scale is used when adjusting the paper feed pressure.

5. LCD Touch Panel

Cautions in using the touch panel

- The touch panel is designed to touch lightly with a finger or a pen (its tip radius is 0.8 or smaller).
Do not press the panel strongly with a finger or push it with any sharp objects (such as a fingernail, ball-point pen, and pin).
- If you perform the following operations, the touch panel may not work even though you are touching it. Additionally, note that such operations may cause malfunction of the machine.
 - Operation with the tip of a nail
 - Operation with a foreign object placed on the touch panel
 - Operation with a protective sheet or sticker applied on the touch panel
 - Operation with the touch panel being wet
 - Operation with a finger wet with sweat or water

The following terms are used when explaining screen operation in this document.

Terms	Description
Touch	Lightly touching an item such as a key once with your finger.
Press and hold	Pressing an item such as a key for more than 1 second. The press-and-hold key is surrounded by a double frame ().

6. Screen Configuration

6-1. [Ready] screen/[Processing] screen

The following is the first screen displayed when the power is turned on and the processing screen. When the [Initial] setting is other than [Ready], the screen that you set is displayed.

[Ready] screen

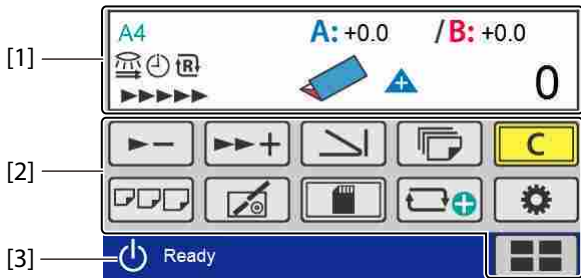

[Processing] screen

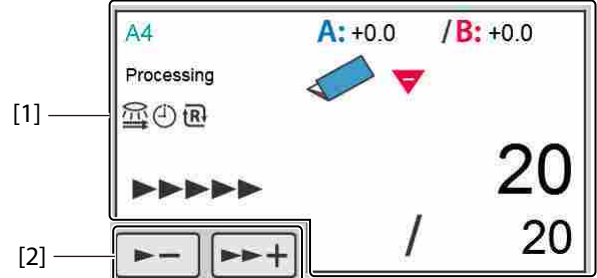

No.	Name	Function
[1]	Touch panel display	Icons and numerical values of set contents are displayed, such as the paper size and folding mode. ☞ "6-1-1. Touch panel display" (p.13)
[2]	Touch panel operation section	Contains keys to change settings such as processing speed and folding mode. ☞ "6-1-2. Touch panel operation section" (p.16)
[3]	Page name	The name of the displayed page. The name is displayed on all the screens except the screen when an error occurs and the processing screen.

6-1-1. Touch panel display

[Ready] screen

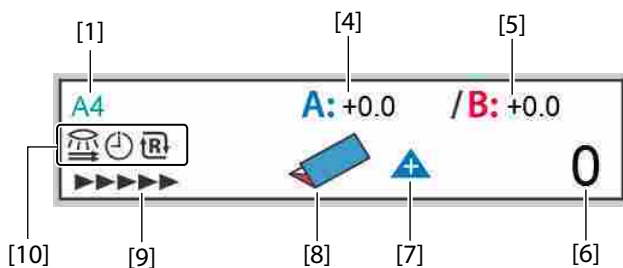

[Ready] screen (custom fold)

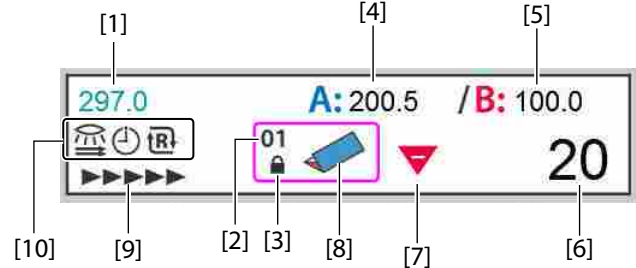



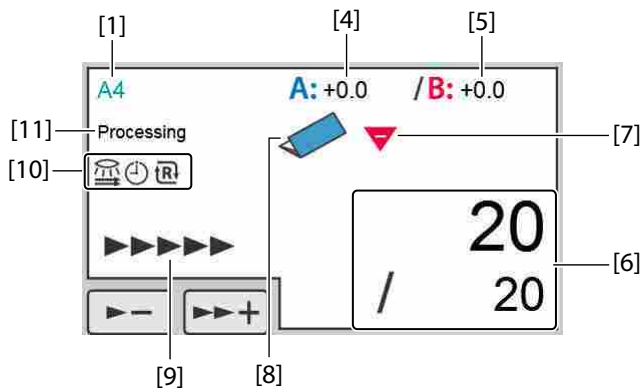



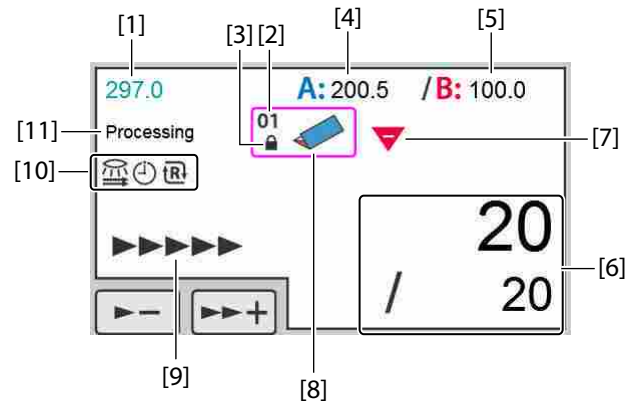



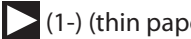







[Processing] screen



[Processing] screen (custom fold)



No.	Name	Function
[1]	Paper size	Displays the detected standard paper size. A3/B4/A4/B5/A5/B6 (For EU) LGR(double letter)/LGL(legal)/LTR(letter)/STMT(statement)/INV(invoice) (For NA) When non-standard paper or custom folding is set, the paper length is displayed.
[2]	Saved data number	Displays the number of saved custom folding data read and used, or the number assigned when custom folding data was newly created and saved. Data is saved with the following numbers: 1 to 30 (*1) 1 to 15 (*2) When data is newly created but not saved, [00] is displayed.
[3]	Saved data lock	Displayed when saved custom folding data is locked.
[4]	Folding dimension A position adjustment	Displays the position adjustment value of folding plate A. When in custom folding or stopper fixed mode, folding dimension A is displayed. Setting range: -5.0 to +5.0 (mm)/-0.197 to +0.197 (inch)
[5]	Folding dimension B position adjustment	Displays the position adjustment value of folding plate B. When in custom folding or stopper fixed mode, folding dimension B is displayed. Setting range: -5.0 to +5.0 (mm)/-0.197 to +0.197 (inch)
[6]	Counter	Displays current counter. Setting range: 0 to 99999 (sheet)
[7]	Count mode	Displays counter mode (addition or subtraction). ▲ Count up ▼ Count down
[8]	Folding mode	Displays the folding mode currently set. When in custom folding or stopper fixed mode, displays a brief shape of the folding form.

No.	Name	Function
[9]	Processing speed	Displays processing speed currently set. The processing speed is not displayed during [Ejecting Paper]. Setting range: 1- to 6+ (speed)  (1-) (thin paper)  (1)  (2)  (3)  (4)  (5)  (6)  (6+) (thick paper)
[10]	Special function display	Displays special functions currently set.  Double-feed detection is set. (optical sensor)  State where the test folding is not performed.  Interval function is set.  The refold mode is set.  Hand feed is set (*3)  The stopper fixation mode is set.  Double-feed detection is set.  State where the test folding is performed.  Double-feed detection is set. (ultrasonic sensor) (*1) (*3)  Double-feed detection is set. (optical sensor) Double-feed detection is not performed because the paper length is 148.0 mm/5.83 inches or less.
[11]	Processing display	Displays current processing content. Testing Processing Idling Ejecting Paper

(*1) DF-999/DF-999A

(*2) DF-990/DF-990A

(*3) Option

6-1-2. Touch panel operation section



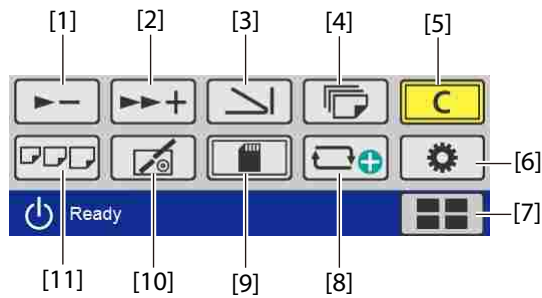



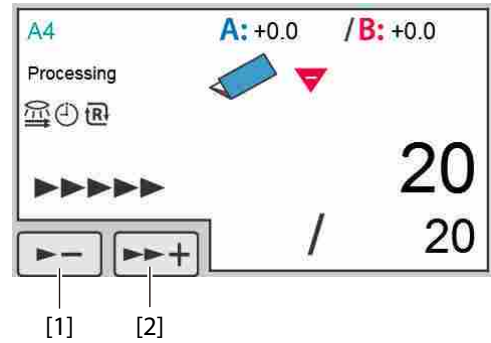







[Ready] screen



[Processing] screen





No.	Name	Function
[1]	(Processing speed down) key	The processing speed is slowed each time the key is touched. When processing speed is set to "1-", the key is grayed out and cannot be operated. Adjustable range: 1- to 6+
[2]	(Processing speed up) key	The processing speed is sped up each time the key is touched. When processing speed is set to [6+], the key is grayed out and cannot be operated. Adjustable range: 1- to 6+
[3]	(Folding mode selection) key	When the key is touched, the [Folding Mode] screen is displayed. When the machine is set in custom folding mode, you can switch the folding mode to standard folding of non-standard paper by using this key.
[4]	(No. of Sheet setting) key	The [No. of Sheet] screen is displayed when the key is touched.
[5]	(clear) key	Press and hold to clear the counter. When a numerical value is entered, the value is set to the initial value.

No.	Name	Function
[6]	 (Custom screen) key	<p>Displays icons set in the custom screen. The set screen is displayed when the key is touched. However, it is not displayed when stopper fixed mode, manual feed mode (*) is set.</p> <p> (Standard folding) DF-999/DF-999A: The [Folding Mode] screen of [Standard Fold] is displayed. However, when automatic paper size detection is turned off, the [Standard Size] screen is displayed. DF-990/DF-990A: The [Folding Mode] screen of [Standard Size] is displayed.</p> <p> (Standard folding of non-standard paper) The [Paper Length] input screen of [Standard Fold for Non-Standard Size] is displayed.</p> <p> (Custom folding) The saved data selection screen of [Custom Fold] is displayed.</p> <p> (Function settings) The [Function Settings] screen is displayed.</p> <p> (Language setting) The [Language] setting screen is displayed, and you can change the language displayed on the touch panel. When the [Language] is set on the custom screen, the custom key is displayed in stopper fixed mode (*), and manual feed mode (*).</p>
[7]	 (Basic settings) key/  (Function settings) key	<p> (Standard folding, Standard folding for non-standard size, Custom folding) The [Basic Settings] screen is displayed when the key is touched.</p> <p> (Stopper fixed mode, Manual feed mode (*)) The [Function Settings] screen is displayed when the key is touched.</p>
[8]	 (Custom folding)	<p>The [Paper Length] input screen of [Custom Fold] is displayed. However, it is not displayed when custom folding, stopper fixed mode, manual feed mode (*) is set.</p>
[9]	 (Save) key	<p>Settings can be saved such as position adjustment of standard fold, position of stacker roller, new non-standard paper setting and folding setting of custom fold. However, when adjustment values is not changed, the key is grayed out and cannot be operated. However, it is not displayed when stopper fixed mode (*) is set.</p>
[10]	 (Adjustment) key	<p>The [Fold Position] screen is displayed. Locked custom fold, stopper fixed mode and can also be adjusted. When automatic paper size detection (DF-999/DF-999A) is turned on, paper size is not detected, and the key is grayed out and cannot be operated.</p>
[11]	 (Paper size) key	<p>The [Paper Length] input screen is displayed when the machine is in one of these modes: Standard folding of standard paper (DF-999/DF-999A), standard folding of non-standard paper, custom folding or manual feed (*). However, it is not displayed in custom folding mode. When in standard folding of standard paper (DF-990/DF-990A), the [Standard Size] screen is displayed.</p>

(*) Option

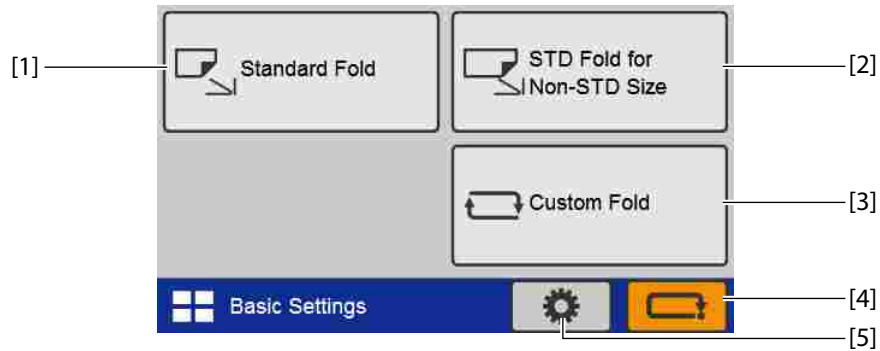
6-2. [Basic Settings] screen



No.	Name	Function
[1]	Standard Fold	Sets the standard folding mode. The [Folding Mode] screen (*1) or [Standard Size] screen (*2) is displayed. However, the [Folding Mode] screen is not displayed depending on the content to be set.
[2]	STD Fold for Non-STD Size	Sets the standard folding mode for non-standard paper. The [Paper Length] input screen is displayed.
[3]	Custom Fold	Sets the custom folding mode. The [Custom Fold] screen is displayed.
[4]	 (Cancel) key	Returns to the previous screen.
[5]	 (Function settings) key	The [Function Settings] screen is displayed.



(*1) DF-999/DF-999A

(*2) DF-990/DF-990A

6-3. [Standard Size] select screen

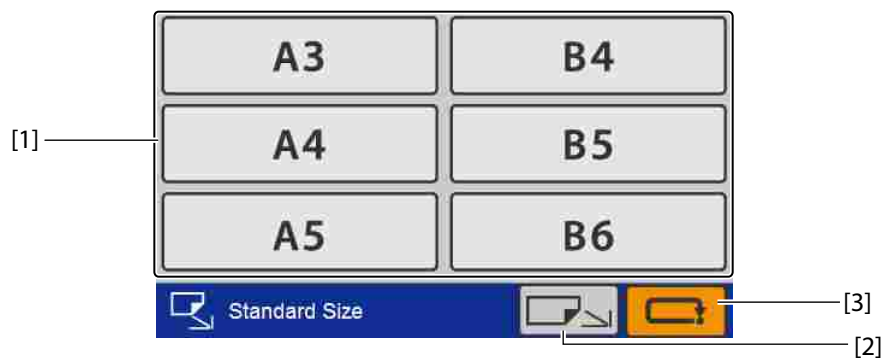





DF-990/DF-990A displays this screen, but DF-999/DF-999A does not display this screen since it has a paper size detection function. However, when automatic paper size detection is turned off, it will be displayed.

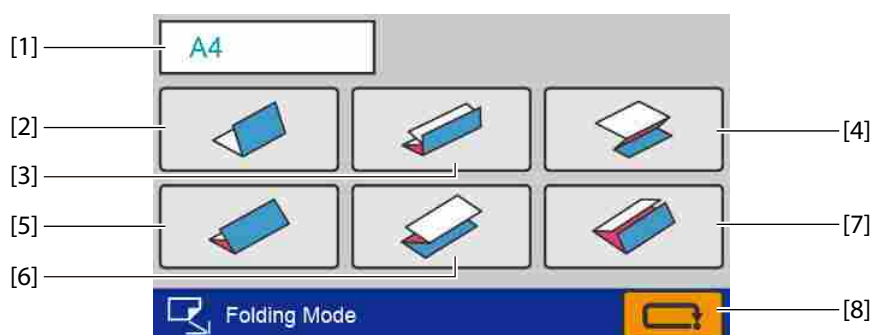

No.	Name	Function
[1]	Standard paper size key	Set the standard paper size to be used. Depending on the set mode, there are restrictions on the paper that can be used. In that case, keys of standard paper sizes that cannot be used are grayed out and cannot be operated.
[2]	 (Non-standard size switching) key	The paper length input screen is displayed.
[3]	 (Cancel) key	Returns to the previous screen. Press and hold to return to the [Ready] screen.

6-4. [Folding Mode] select screen





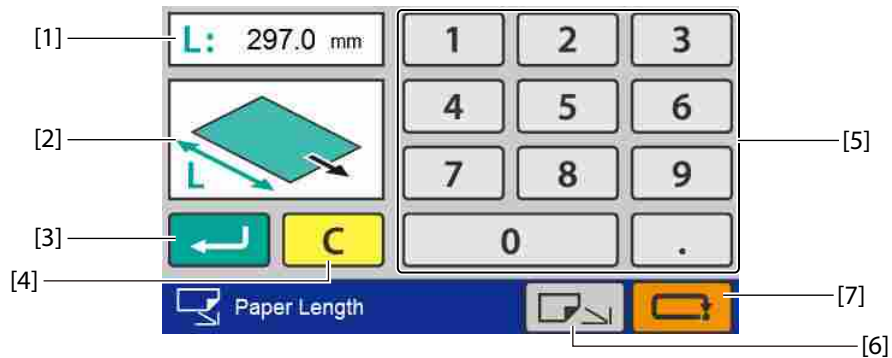

No.	Name	Function
[1]	Paper size display	Displays the currently set standard size. When non-standard size paper is set, the paper length is displayed.
[2]	 (Single fold) key	Set the folding mode as single fold.
[3]	 (Double fold) key (*)	Set the folding mode as double fold.
[4]	 (Irregular accordion fold) key (*)	Set the folding mode as irregular accordion fold-out.
[5]	 (letter fold) key (*)	Set the folding mode as letter fold.
[6]	 (Accordion fold) key (*)	Set the folding mode as accordion-fold.
[7]	 (Gate fold) key (*)	Set the folding mode as gate fold.
[8]	 (Cancel) key	Returns to the previous screen without saving the input content.

(*) Depending on the paper length that you set, the keys that cannot be used are grayed out and cannot be operated.

6-5. [Paper Length] input screen



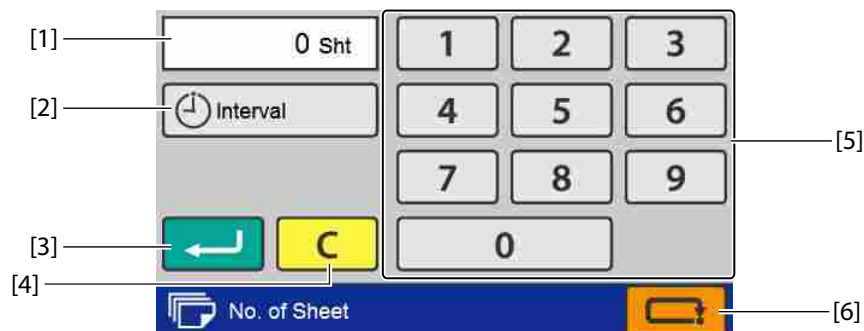

No.	Name	Function
[1]	Paper length setting value	Displays the currently set paper length.
[2]	Preview screen	Displays the position of the input value.
[3]	 (Return) key	Saves the input value and transits to the next screen. When you touch the key while the input value is outside the specification range, the value within the range that you can input is displayed on the preview screen.
[4]	 (Clear) key	Sets the input value to "0".
[5]	Numeric keypad	Inputs the value. Setting range: 105.0 to 457.2 mm/4.13 to 18.00 inches
[6]	 (Standard size switching) key	DF-999/DF-999A: Displays either the standard paper size selection screen, [Ready] screen or custom fold editing screen. The displayed screen differs depending on the screen before transition. When the key is grayed out, it cannot be operated because a standard paper size is not detected. DF-990/DF-990A: The standard size selection screen is displayed.
[7]	 (Cancel) key	Returns to the previous screen without saving the input content. Press and hold to return to the [Ready] screen.

6-6. [No. of Sheet] input screen



No.	Name	Function
[1]	Sheets to be folded setting value	Displays the currently set number of sheets to be folded.

No.	Name	Function
[2]	[Interval] key	The [Interval] screen is displayed. ☞ Chapter 3 "8-3. Interval function" (p.61)
[3]	 (Return) key	Saves the input value and returns to the [Ready] screen.
[4]	 (Clear) key	Sets the input value to "0".
[5]	Numeric keypad	Inputs the value. Input range:0 to 99999 (sheets)
[6]	 (Cancel) key	Returns to the [Ready] screen without saving the input content.

6-7. [Fold Position] screen



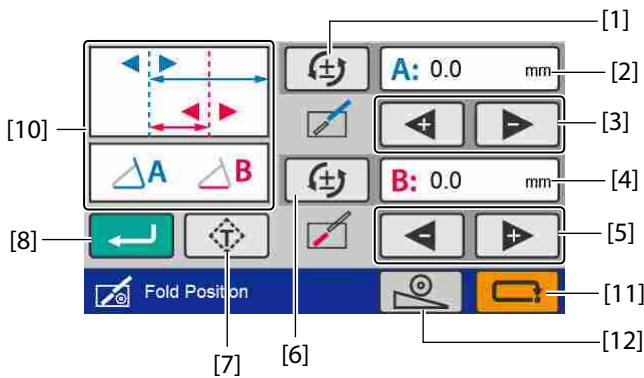

Standard fold/standard folding of non-standard paper

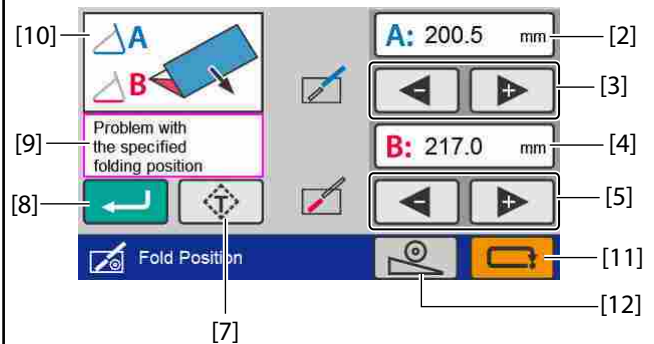

Custom folding





No.	Name	Function
[1]	Folding A reversal	Reverses [+] and [-] of folding dimension A. When the value after being reversed is outside the specification range, it is corrected to the nearest value within the specification range. When in custom folding or stopper fixed mode, it is not displayed.
[2]	Folding A position adjustment value/Folding dimension A position (*)	Displays the Standard folding: Folding A position adjustment value. Displays the Custom folding: Folding dimension A. When you touch the key, the numeric keypad is displayed, which enables you to input values.
[3]	Folding A position adjustment key (*)	Adjusts the position of the folding stopper of folding plate 1. [+] Raises the position of folding A. When pressed and held, the value continues to increase automatically within the setting range. [-] Lowers the position of folding A. When pressed and held, the value continues to decrease automatically within the setting range.
[4]	Folding B position adjustment value/Folding dimension B position (*)	Displays the Standard folding: Folding B position adjustment value. Displays the Custom folding: Folding dimension B. When you touch the key, the numeric keypad is displayed, which enables you to input values.

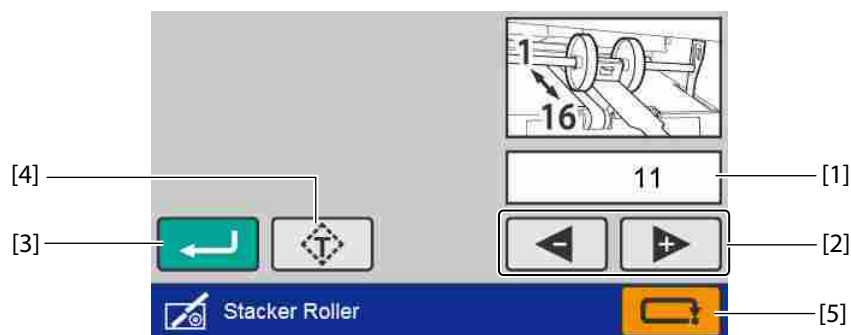

No.	Name	Function
[5]	Folding B position adjustment key (*)	Adjusts the position of the folding stopper of folding plate 2. [+] Raises the position of folding B. When pressed and held, the value continues to increase automatically within the setting range. [-] Lowers the position of folding B. When pressed and held, the value continues to decrease automatically within the setting range.
[6]	Folding B reversal	Reverses [+] and [-] of the folding dimension B. When the value after being reversed is outside the specification range, it is corrected to the nearest value within the specification range. When in custom folding or stopper fixed mode, it is not displayed.
[7]	 (Test) key	Executes test fold before saving the adjusted value of the folding stopper position. It is not displayed when in manual feed mode (option).
[8]	 (Return) key	Saves the input value and returns to the [Ready] screen. When you touch the key while the input value is outside the specification range, the value within the range that you can input is displayed in the Outline of folding dimension.
[9]	Warning message	When the input value is outside the specification range, a warning message is displayed.
[10]	Outline of folding dimension	The outline of folding dimension for folding form is displayed.
[11]	 (Cancel) key	Returns to the [Ready] screen without saving the input content.
[12]	 (Stacker roller) key	The [Stacker Roller] screen is displayed. When the combination of position adjustment values is invalid, a warning message is displayed and the [Stacker Roller] screen is not displayed.

(*) It is not displayed depending on the content to be set.

6-8. [Stacker Roller] screen









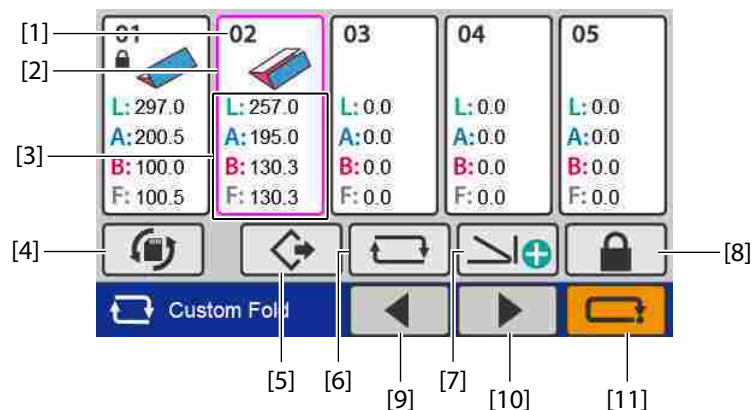

No.	Name	Function
[1]	Stacker roller position	Displays position of stacker roller.
[2]	Stacker roller adjustment key	[+] Raises the position of stacker roller. When pressed and held, the value continues to decrease automatically. [-] Lowers the position of the stacker roller. When pressed and held, the value continues to increase automatically.
[3]	 (Return) key	Saves the input value and returns to the previous screen.

No.	Name	Function
[4]	 (Test) key	Executes test fold before saving the adjusted value of the stacker roller position. It is not displayed when in manual feed mode (option).
[5]	 (Cancel) key	Returns to the previous screen without saving the input value.

6-9. [Custom Fold] screen

Saved data selection screen





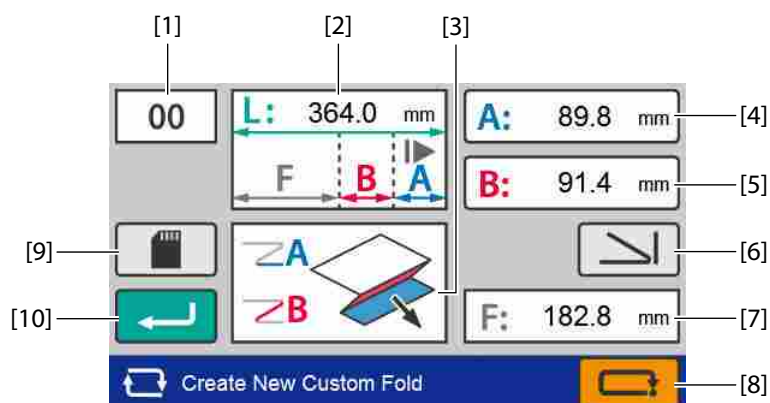

No.	Name	Function
[1]	Saved data number/Saved data lock display	 "6-1-1. Touch panel display" (p.13)
[2]	Selection frame	Touch to select the saved data you want to use. The color of the frame of the selected saved data changes.
[3]	Custom fold data	Displays the length of each fold saved. L: Paper length A: Folding A length B: Folding B length F: Finishing length
[4]	 (Switch to save screen) key	Displays the [Save] screen.
[5]	 (Open) key	Reads the selected saved data and returns to the top screen. When non-saved data is selected, the key is grayed out and cannot be operated.
[6]	 (Edit) key	Displays the [Paper Length] input screen for the selected saved data.
[7]	 (Create new) key	Creates new data.
[8]	 (Lock/Unlock) key	Locks or unlocks the selected saved data. Locked data cannot be deleted. When non-saved data is selected, the key is grayed out and cannot be operated.
[9]	 (Page backward) key	Moves to the previous page.
[10]	 (Page forward) key	Moves to the next page.

No.	Name	Function
[11]	 (Cancel) key	Returns to the [Basic Settings] screen. Press and hold to return to the [Ready] screen.

Editing screen









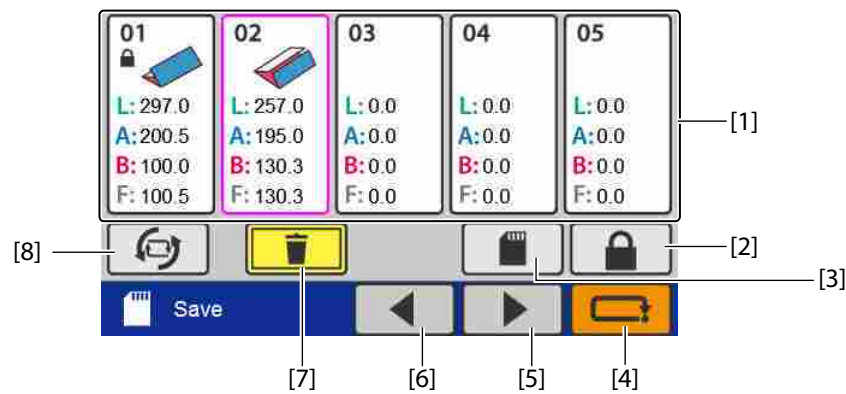

No.	Name	Function
[1]	Saved data number display	Displays the number of the data being edited. When data is newly created, [00] is displayed.
[2]	Paper length	Displays the currently set paper length.
[3]	Folding form outline display	Displays a brief shape of the folding form.
[4]	Folding A setting	Displays currently set folding A length. When the key is touched, the [Edit] screen of folding A is displayed. Setting range: 42.0 to *** mm/1.65 to *** inch ***: 325.0 mm/12.80 inches or "Paper length + 5.0 mm/+0.197 inch", whichever is shorter.
[5]	Folding B setting	Displays the currently set folding B length. When the key is touched, the [Edit] screen of folding B is displayed. When folding B is not used, set as 0 mm. Setting range: 0/47.0 to *** mm/1.85 inches ***: 217.0 mm/8.54 inches or "Paper length + 5.0 mm/+0.197 inch", whichever is shorter.
[6]	 (Folding mode selection) key	When the key is touched, the [Folding Mode] screen is displayed. When folding mode is set, value of the folding A and folding B is input automatically according to the paper size and folding form, and display returns to this screen.
[7]	Finishing size	Displays the estimated value of the finishing length based on the input value and folding form.
[8]	 (Cancel) key	When you enter this screen from the [Basic Settings] screen, the display returns to the [Paper Length] input screen. In this case, the values of folding A and folding B that you have input are temporarily saved, and the values are restored when you save the paper length. When you touch the  key on the [Paper Length] input screen, however, the temporarily stored values are discarded. Press and hold to return to the [Ready] screen.

No.	Name	Function
[9]	 (Save) key	Saves the input value and displays the [Save] screen. When the combination of input values is in the following conditions, the data becomes invalid and cannot be saved. - The value of folding A is set to [0]. - Folding A is larger than L (the paper length). - Folding B is larger than both folding A and "L - folding A".
[10]	 (Return) key	Saves the input value and returns to the [Ready] screen. The input value is not saved.



[Save] screen

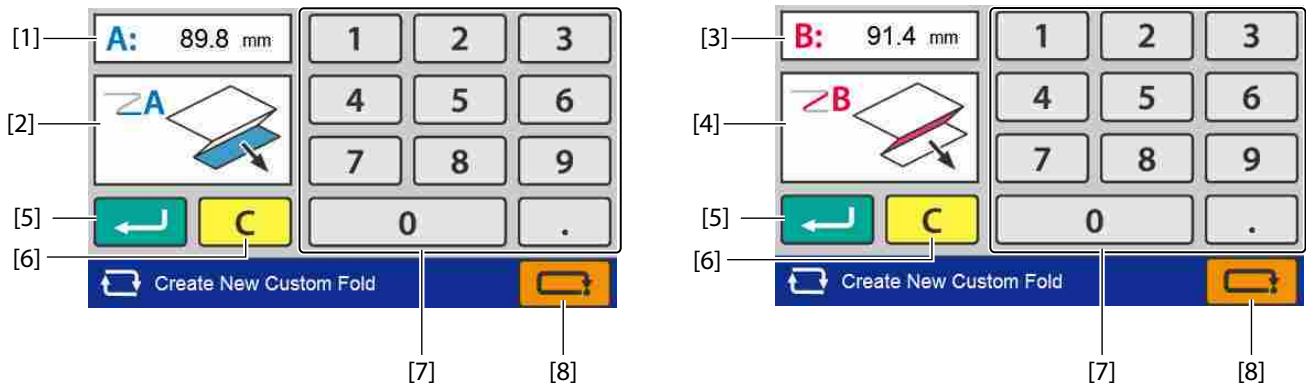

No.	Name	Function
[1]	Custom fold saved data	 "6-9. [Custom Fold] screen" (p.23)
[2]	 (Lock/Unlock) key	
[3]	 (Save) key	Saves the setting content. When creating new data, custom fold data is saved in the free space. When there is no free space, the key is grayed out and cannot be operated. When saved data is edited, data is overwritten and saved. When you enter this screen from the [Ready]/[Basic Settings] screen, the display returns to the [Ready] screen.
[4]	 (Cancel) key	Returns to the custom fold edit screen. Press and hold to return to the [Ready] screen.
[5]	 (Page backward) key	 "6-9. [Custom Fold] screen" (p.23)
[6]	 (Page forward) key	
[7]	 (Delete) key	Press and hold to delete the selected saved data. While non-saved data or locked data is selected, the key is grayed out and cannot be operated.
[8]	 (Switch to the saved data selection screen) key	Displays the saved data selection screen.

6-10. Folding A/Folding B input screen



No.	Name	Function
[1]	Folding A setting value display	Displays the currently set folding A value.
[2]	Folding A outline display	Displays the position of folding A on the paper. When the input value is outside the specification range, a warning message is displayed.
[3]	Folding B setting value display	Displays the currently set folding B value.
[4]	Folding B outline display	Displays the position of folding B on the paper. When the input value is outside the specification range, a warning message is displayed.
[5]	 (Return) key	Saves the input value and returns to the [Custom Fold] screen.
[6]	 (Clear) key	Sets the input value to "0".
[7]	Numeric keypad	Inputs the value. Setting range Folding A: 42.0 to *** mm/1.65 to *** inches ***: 325.0 mm/12.80 inches or "Paper length + 5.0 mm/+0.197 inch", whichever is shorter. Folding B: 0/47.0 to *** mm/1.85 to *** inches ***: 217.0 mm/8.54 inches or "Paper length + 5.0 mm/+0.197 inch", whichever is shorter.
[8]	 (Cancel) key	Returns to the previous screen without saving the input content. Press and hold to return to the [Ready] screen.

6-11. [Function Settings] screen

Selection screen 1

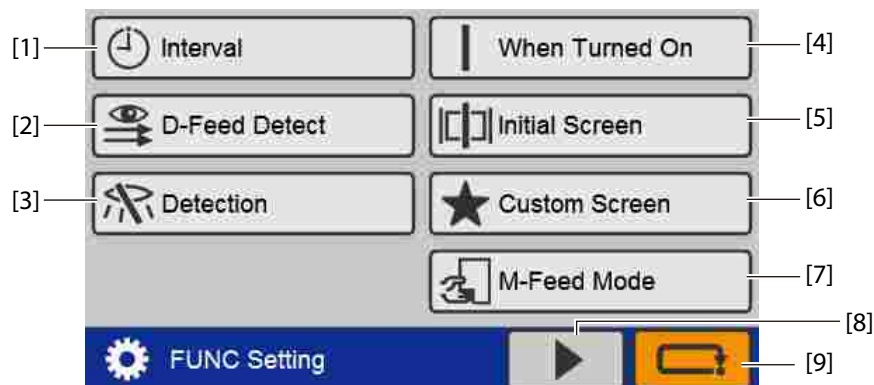

No.	Name	Function
[1]	Interval	Sets whether to use the interval (division) function or not. ☞ Chapter 3 "8-3. Interval function" (p.61)
[2]	D-Feed Detect (Double Feed Detect)	Sets whether to perform double feed detection or not. ☞ Chapter 3 "8-4. Double-feed detection" (p.63)
[3]	Detection	Sets whether to perform paper stacked/standard size detection or not. ☞ Chapter 3 "8-5. Detection" (p.65)
[4]	When Turned On	Sets the operation mode when the power is turned on. ☞ Chapter 3 "8-6. Initial" (p.65)
[5]	Initial Screen	Sets the initial screen when the power is turned on. ☞ Chapter 3 "8-7. Initial screen" (p.67)
[6]	Custom Screen	Sets a custom screen. ☞ Chapter 3 "8-8. Custom screen" (p.68)
[7]	M-Feed Mode (Manual Feed Mode)	Sets whether to use manual feed mode. Displayed only when the DF HAND FEED KIT is registered as an optional item. ☞ Chapter 4 "3. Manual Feed Mode Setting" (p.77)
[8]	Display screen switching key	Touching this key switches the screen to the 2nd page.
[9]	 (Cancel) key	When touched, the display returns to the [Basic Settings] screen. Press and hold to return to the [Ready] screen.

Selection screen 2

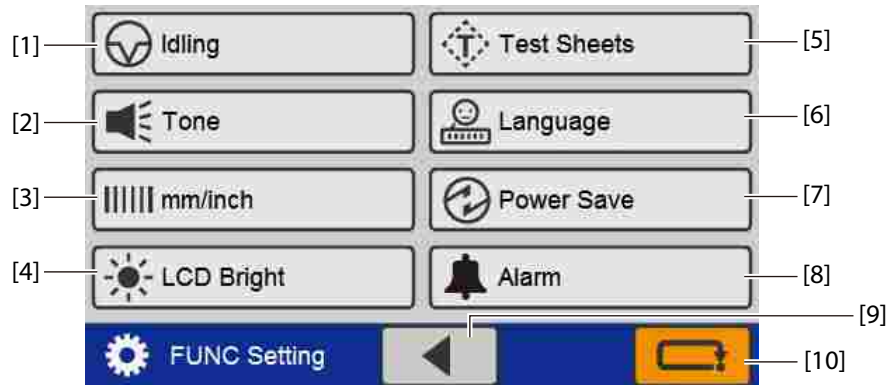

No.	Name	Function
[1]	Idling	Sets whether or not to perform idling operation. ☞ Chapter 3 "8-9. Idling" (p.69)
[2]	Tone	Sets whether to enable or disable the buzzer (key operation sound on the control panel). However, the buzzer that sounds when an abnormality occurs will sound even if the setting is disabled. ☞ Chapter 3 "8-10. Tone" (p.70)
[3]	mm/inch	Switches the unit used for paper length. ☞ Chapter 3 "8-11. mm/inch" (p.70)
[4]	LCD Bright	Sets the brightness of the LCD touch panel screen. ☞ Chapter 3 "8-12. LCD bright" (p.71)
[5]	Test Sheets (The Number of Test Sheets)	Sets the number of test feed sheets. ☞ Chapter 3 "8-13. Number of test sheets" (p.72)
[6]	Language	Switches the language displayed on the touch panel. ☞ Chapter 3 "8-14. Language" (p.72)
[7]	Power Save	Sets whether or not to turn off the LCD touch panel screen automatically. ☞ Chapter 3 "8-15. Power saving" (p.73)
[8]	Alarm (*)	Sets whether or not to use an alarm to prevent forgetting to switch off the power. ☞ Chapter 3 "8-16. Alarm (DF-999/DF-999A)" (p.74)
[9]	Display switching key	Touching this key switches the screen to the 1st page.
[10]	 (Cancel) key	When touched, the display returns to the [Basic Settings] screen. Press and hold to return to the [Ready] screen.

(*) DF-999/DF-999A

6-12. Classification of buzzer sounds

In this machine the buzzer sounds in confirmation when setting on the control panel or paper runs out on the paper feed tray. Classification of the sounds is as follows.

“pi”: Operational sound at the time of normal key operation

“pipi”: Warning alarm at the time of mis-operation, mis-feed of paper, or paper empty

“pii”: At the start of folding operation or end of normal folding operation.

Saves changes in various settings. The time when you set the alarm has come.

“piipii”: At the occurrence of an error such as paper jam

“piipiipiipi”: At the occurrence of an error to be asked for Duplo dealer’s assistance

7. Paper Types and Sizes

Paper type

Fine quality paper : 46.5 to 157 g/m² /31.62 to 106.76 lbs

Rough paper, Stencil paper, Recycle paper, Specific art paper, Specific coated paper

Paper size

Standard Paper

The standard paper can be used only when it is stacked in the machine direction.

A3/B4/A4/B5/A5/B6 (For EU), LGR/LGL/LTR/STMT/INV (For NA)

Non-standard paper

[a] 74 to 311 mm/2.91 to 12.24 inches (Width)

[b] 105.0 to 457.2 mm/4.13 to 18.0 inches (Length)

Some limitations in setting and paper quality may be applied depending on paper size.

The A6, A7, or B7 paper can be used as non-standard paper. (For EU)

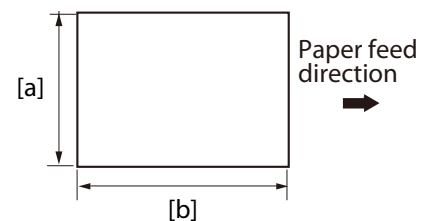

Paper that cannot be used with this machine

- Paper out of specifications
- Curled paper
- Wavy paper

8. Handling Paper

8-1. Paper used

- Make sure that the printing ink on the paper has dried completely prior to use.

- **Wet ink or ink that is not completely dried may stain the folding roller causing trouble such as smearing on paper.**
- **Use of paper printed with special types of ink may cause the folding roller to swell or deform, and folding misalignment may occur.**

- Paper may not be fed smoothly into the folding plate or deformed folding may occur depending on different environmental factors (temperature, humidity), paper ream weight, paper type, paper grain direction if curled paper is used. Make sure to flatten curled paper or paper with folded lines before use.
- Separate the sheets of paper well before stacking them.

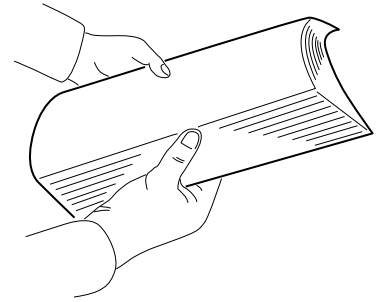

8-2. Precautions on stacking paper

- [a] Do not stack the sheets of paper on the paper feed tray with the sides of sheets unaligned or some sheets protruding from the stack.

This machine has an automatic standard paper size detection function. It automatically detects paper size at the paper feed guides. Therefore, if paper is protruding out from the left or right side, it is unable to detect paper size accurately and may determine standard paper as non-standard. (DF-999/DF-999A)

- [b] Do not stack paper on the paper feed tray with the lead and trail edges unaligned or some sheets protruding out.

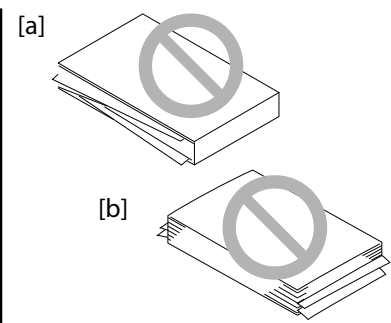
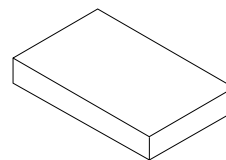

- **Processing with sheets unaligned on the right or left side may cause such trouble as folding misalignment and jamming.**
- **Processing with sheets unaligned on the lead and trail edges may lead to unstable feed causing such trouble as miss-feed and double-feed.**

9. Options

DF HAND FEED KIT

No.	Name	Function
[1]	Hand feed tray	Insertion inlet for feeding paper manually to fold.
[2]	Auxiliary feed guide	Subordinately guides sheets so that the may be fed properly.

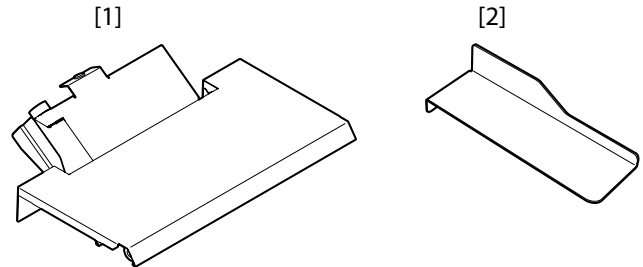

10. Workflow

The flowchart below illustrates the flow of basic operation. For details, refer to the text and relevant pages.

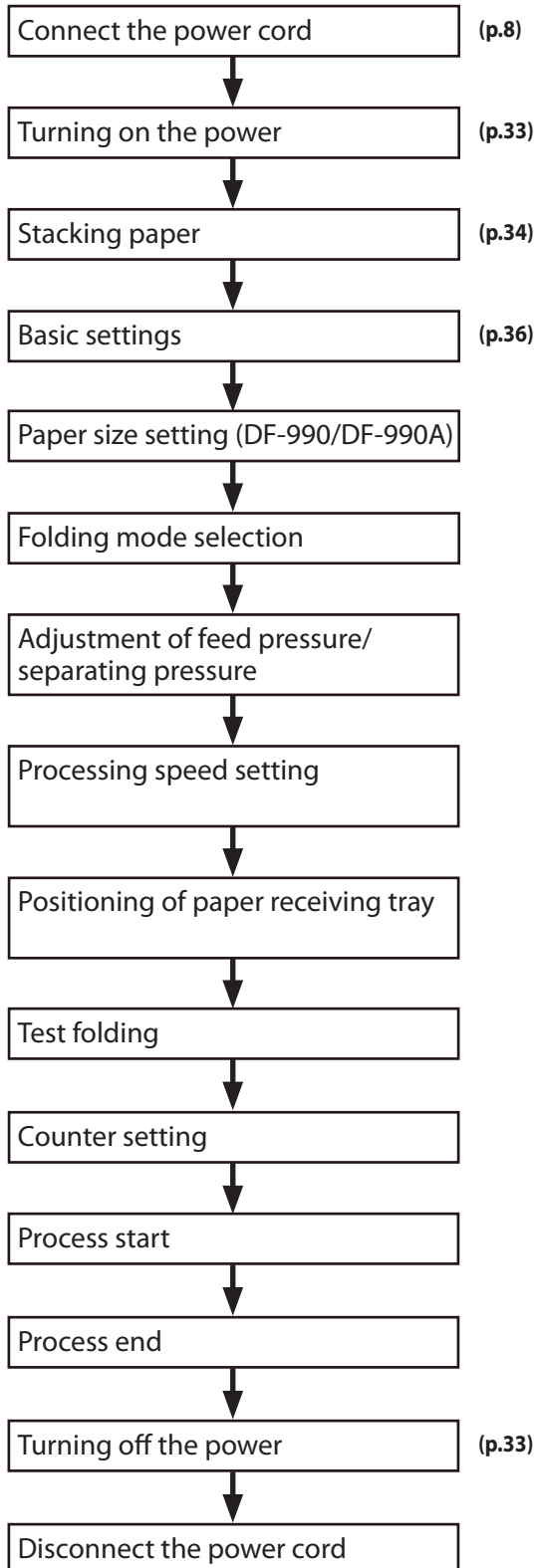

Chapter 2 Basic Operation

1. Turning On/Off the Power

▼ Make sure that the power plug is connected to the wall socket.

1-1. Turning on power

Set the power switch to the “I” side.

 WARNING	
	Do not touch the power switch with wet hands. Otherwise electric hazards may occur.

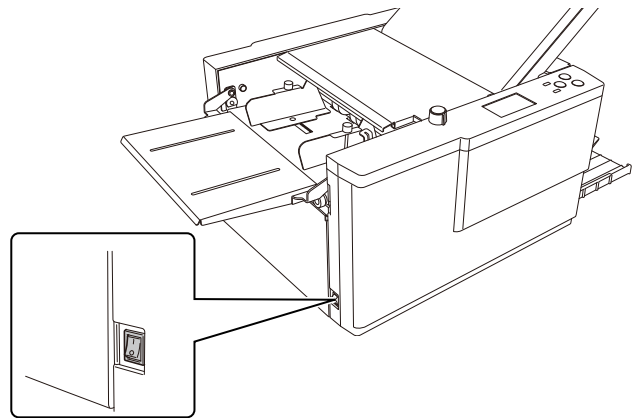

1-2. Turning off power

Set the power switch to the “O” side.

2. Stacking the Paper

2-1. Before stacking paper

Standard folding

There are six types of standard folding modes: single fold, double fold, irregular accordion fold (fold out), letter fold, accordion fold (z fold) and gate fold. Paper is folded as shown below when the paper is placed on the paper feed tray with its print side facing upward.

When paper is stacked with the gray surface on the obverse side and white surface on the reverse side on the paper feed tray, and processing is completed in the standard folding mode, the folded paper is as shown in the figure.

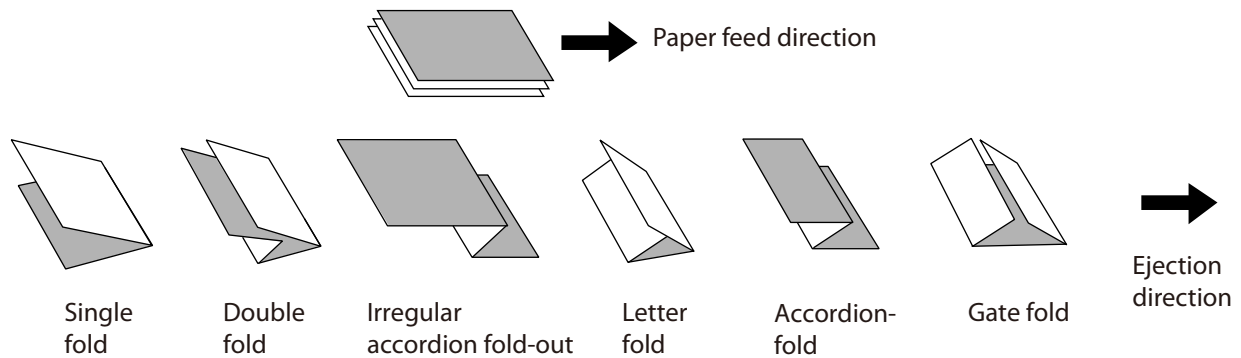

2-2. Stacking paper

⚠ CAUTION

- Do not put fingers inside during operation.**
- Keep away long hair, ties, jewelry and loose clothing.**
- It could cause injury.**

Steps 1 and 6 are not necessary with the DF-999/DF-999A. Move on to steps 2 to 5.

- 1 Raise the paper set lever.**
The paper feed stand will come down to the paper stacking position when the paper set lever is raised.

- 2 Loosen the guide fixing screw.**

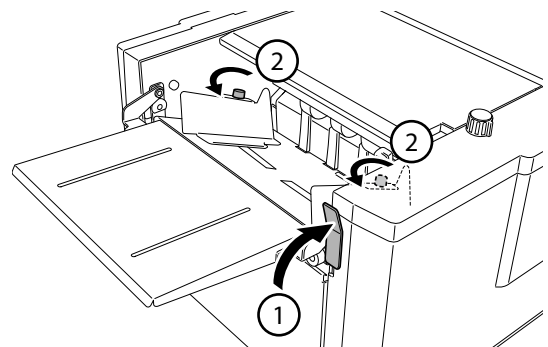

3 Stack paper on the paper feed tray.

Push in the paper until the lead edge touches the paper feed inlet lightly.

Maximum paper stacking height: 46 mm/1.81 inches.

4 Adjust the paper feed guide to match the paper size.

Set the paper feed guide in such a way that it touches the paper lightly.

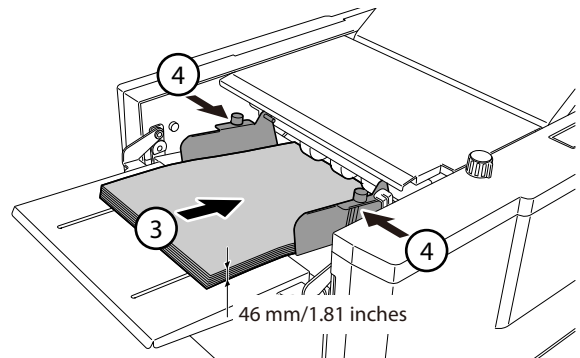

- ! Do not press the paper with the paper feed guides too strongly. Otherwise, paper feed errors such as mis-feed will occur.
- If the guides are positioned incorrectly, the automatic paper size detection function will not work, and the test key and start key, etc. will not operate. (DF-999/DF-999A)

5 Tighten the guide fixing screws.

- ! Make sure to tighten the guide fixing screws on both right and left sides. If the screws are not fixed, the paper feed guide moves during operation, and folding misalignment may occur in the right and left direction.

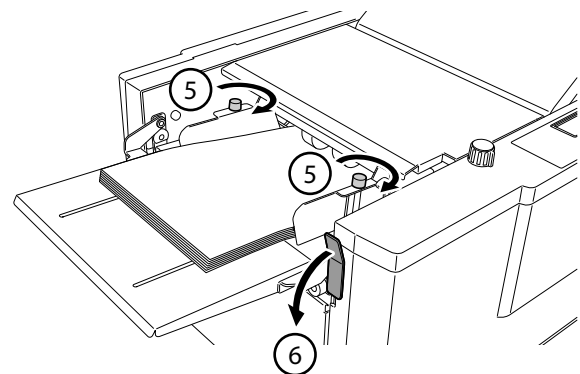



6 Lower the paper set lever.

The paper feed stand will go up to the paper feeding position when the paper set lever is lowered.

- ! When the paper feed tray is not set at the feed position, even if you press the  key or  key, [Position Err Paper Feed Tray] will be displayed and operation will not start. (DF-990/DF-990A)

Automatic rise/descent of the paper feed tray (DF-999/DF-999A)

When paper is stacked on the paper feed tray, the paper feed guides are set, and the  or  key is pressed, the paper feed tray rises automatically.

- ! When using large or heavy paper, the paper feed tray may become over stacked and may not be able to rise due to paper weight. In such cases, stack less paper.



- The paper feed tray descends automatically when paper is removed from the paper feed tray. It will also descend automatically when paper runs out on the paper feed tray during a folding operation.
- When [Detection] is turned off, the paper stacked on the tray is not detected. Therefore, when the operation stops, the paper feed tray goes down automatically even if paper is stacked on the tray.

 Chapter 3 "8-5. Detection" (p.65)

3. Standard Folding of Standard Paper

Method to fold standard paper by setting a mode among standard folding modes displayed on the control panel.

Depending on the thickness of paper, this machine may not be able to process some standard sheets of paper.

! CAUTION	
	Do not put fingers inside during operation.
	Keep away long hair, ties, jewelry and loose clothing.
	It could cause injury.

Automatic detection of standard paper size (DF-999/DF-999A)

When paper for all paper sizes is stacked in the machine direction shown in the figure, paper is detected as standard paper.

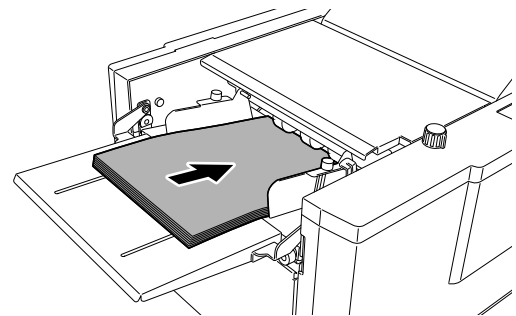

! When paper of standard paper size is stacked on the paper feed tray in the sideways, the paper size is detected as wrong paper size. Use paper as non-standard paper when stacking paper in the sideways.

For the use of non-standard paper, refer to Chapter 3 “2. Standard Folding of Non-Standard Paper” (p.46).

The operating procedure will be explained using the example of when the paper size is “A4” and the folding mode is “Single Fold.”

1 Touch the  key on the [Ready] screen.

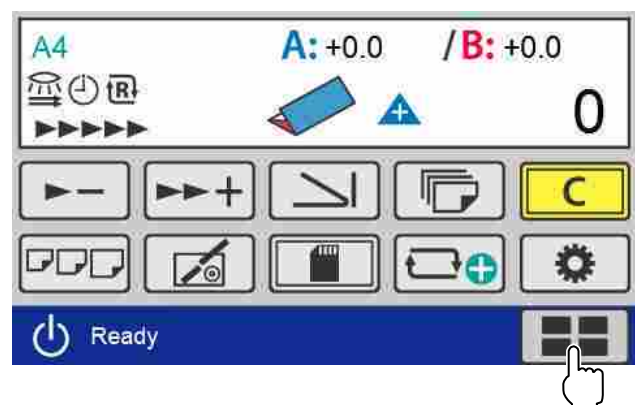

2 Touch the [Standard Fold] key.

DF-999/DF-999A

The Folding Mode setting screen is displayed. Proceed to step 4.

If the paper size is not displayed even when the standard paper size is used, the paper feed guide is positioned incorrectly.

If the folding mode is not displayed, adjust the paper feed guide to the correct position.

DF-990/DF-990A

The Standard Paper Size setting screen is displayed.

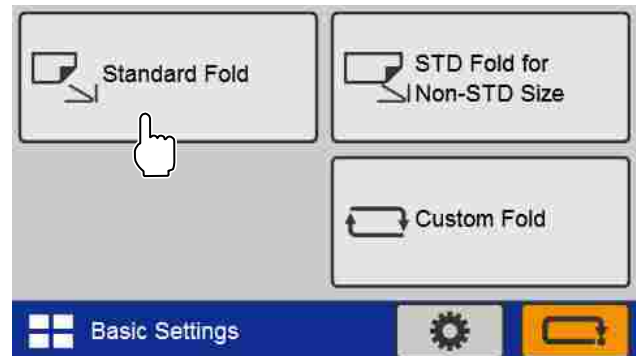

3 Touch the [A4] key.

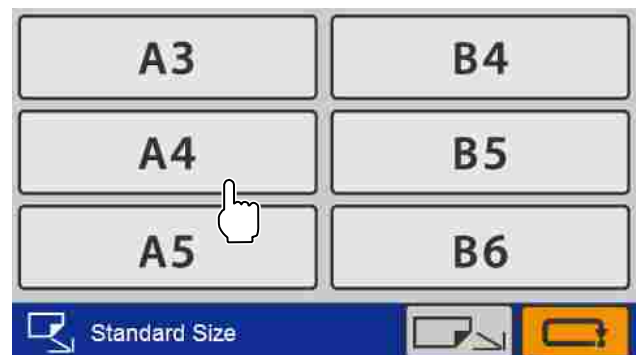

4 Touch the [A4] key.

Return to the Ready screen.

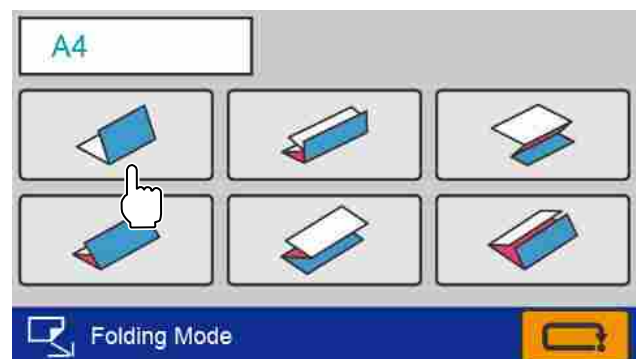

5 Set the feeding pressure adjustment lever to [0].

- As the value of the scale increases, the paper feed pressure increases. As the value decreases, the paper feed pressure decreases.
- When paper mis-feed occurs, increase the paper feed pressure to [1] instead of [0].
- When double-feed occurs, lower the paper feed pressure from [0] to [-1].

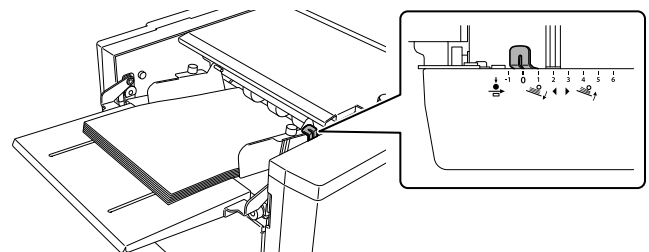

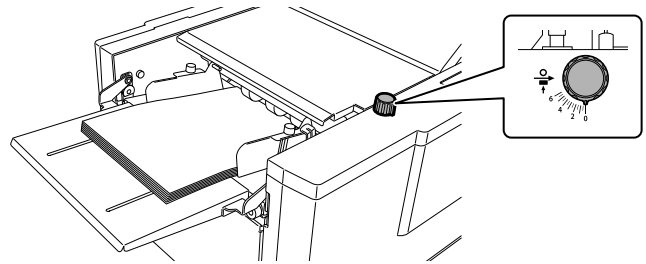

6 Set the separating pressure adjustment dial to [0].

- Paper separating pressure increases as the scale value increases, and paper separating pressure decreases as the scale value decreases.
- When double-feed occurs, increase the separating pressure by 0.5 on the scale.



7 Touch the or key to set the processing speed.

- If paper is folded abnormally, and conveyance motor error occurs when processing thick paper, set the processing speed referring to "Thick paper mode".
 Chapter 3 "8-1. Thick paper mode" (p.61)
- When paper jam or abnormal folding occurs by using thin and flimsy paper, adjust the processing speed referring to "Thin paper mode".
 Chapter 3 "8-2. Thin paper mode" (p.61)
- The processing speed can be changed during folding process or in the idling state. However, folding misalignment may be caused by changing the processing speed largely.

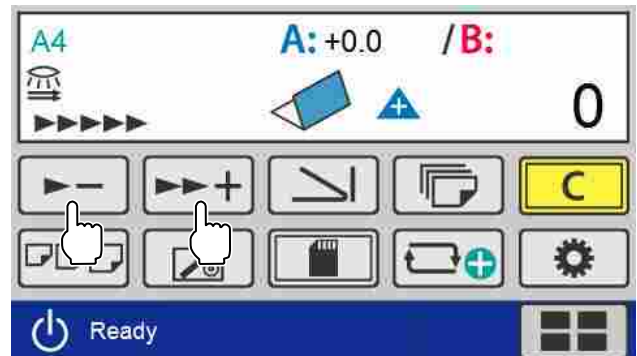

8 Adjust the position of the paper receiving tray.

Set to [A] to stack ejected paper diagonally.
 Set to [B] to stack ejected paper straight.
 Refer to Chapter 3 "7. Stacking the Folded Paper" (p.60).

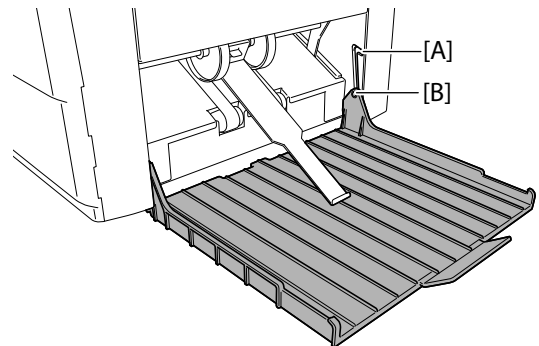

In the following cases, proceed to step 10.

- Set [Folding Mode] to single fold.
- Set the paper receiving tray to [B].
 The paper support guide cannot be used when the paper receiving tray is set to [B].
- Although the paper receiving tray is set to [A], the paper support guide is not used.

9 Attach the paper support guide [A] to the paper receiving tray from the paper ejecting section.

- Match the concave sections [b] (two points) on the reverse side of the paper support guide [A] with the convex section [c] on the paper receiving tray to attach the paper support guide.

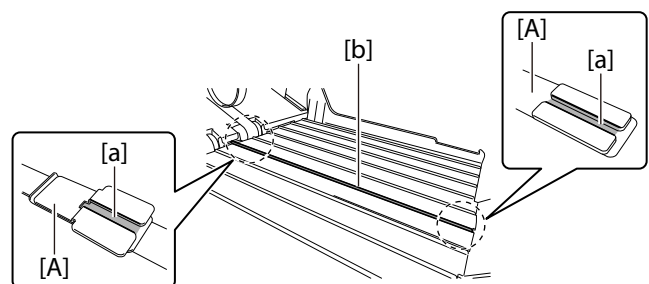

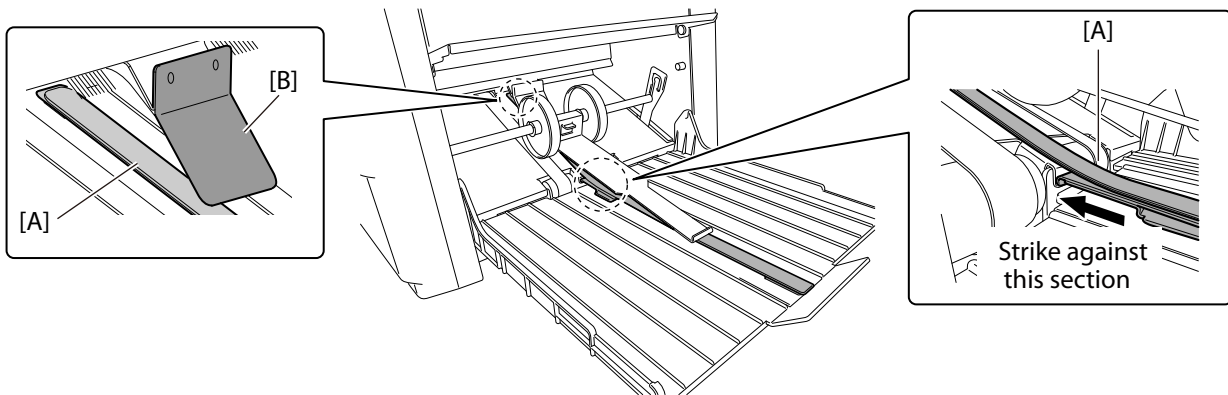

- Be sure to attach the paper support guide to the paper ejecting section and paper receiving tray through the lower sections of the stacker roller and outfeed guide [B].



10 Press the key.

Test folded paper are not counted in the number of sheets processed.



- DF-999/DF-999A
If this machine does not start by pressing the  key, automatic detection of paper size may not function. Check the paper feed guide is set appropriately to the scale of paper size.
- DF-990/DF-990A
If this machine does not start by pressing the  key, check the paper set lever is lowered.

11 Check the finish of test folding.

Check the last sheet of test folded paper for folding misalignment.

When folding misalignment occurs, refer to Chapter 3 "1. Correcting Folding Misalignment" (p.42).

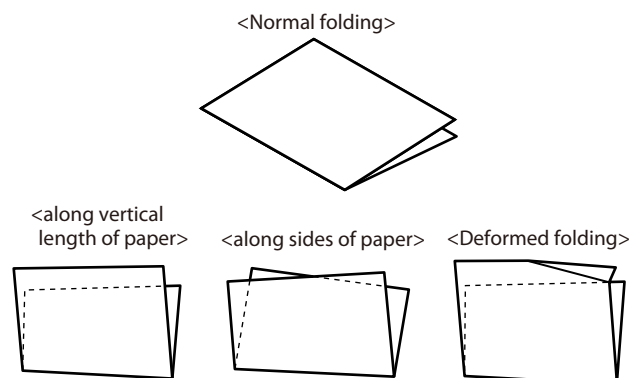

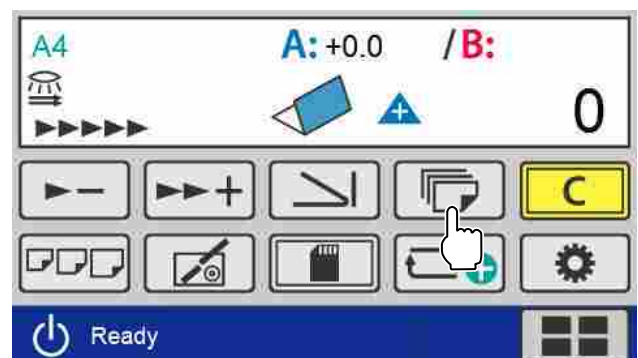

12 Touch the key.

Displays the number of sheets input screen.



Count up

Touch the key.



- After setting the counter to [0], start the operation.
- If you press the  key without setting the counter to [0], the paper folding operation restarts and the number of sheets set for processing is incremented from the current value.
- When the count display reaches [99999], the machine stops operating. To continue paper folding processing, return the counter display to [0] and then press  key.



Count down



Using the numeric keypad, enter the number of sheets to be folded →

Touch the key.

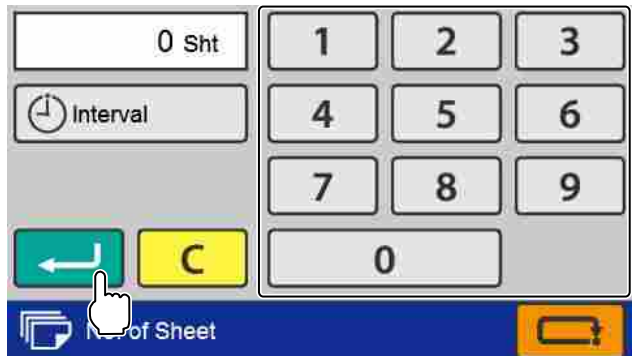
- The maximum display digit number is 5 digits (99999).
- When processing of the set number of sheets to be folded is completed, the machine stops operation and the count display returns to the set number of sheets.
- When you touch the  key and set the counter to [0], the usage method is changed back from "subtraction" to "addition".
- If you touch the  key without pressing the  key, the folding operation restarts and the number of sheets set for processing is counted down from the current value.



13 Press the key to start folding.

- Press the  key to interrupt or stop operation. Press the  key again to restart operation.
- If the paper in the paper feed tray runs out, the machine is put on standby. After stacking paper, press the  key to restart the operation.
- When double-feed or paper size error occurs during folding operation, the fed paper is processed and ejected, but the number of processed sheets will not be counted.
- When paper jams at the ejecting section, the paper detected as paper jam will be counted, but the following paper will not be counted.

4. Storage of Machine

Store the machine as follows, when it is not used.

- 1** Turn off the power switch.



- 2** Disconnect the power plug from the outlet.



- 3** Remove the power cord from this machine.

- 4** Close the support paper feed tray.

- 5** Remove the auxiliary paper ejection guide and paper support guide.

Store the paper support guide with caution in order not to lose.

- 6** Return the height of the stacker roller to the standard position.

 Chapter 3 "6-1. Changing stacker roller height" (p.58)

- 7** Hang the hook section of the paper receiving tray.

- 8** Hang the auxiliary paper ejection guide on the paper receiving tray.

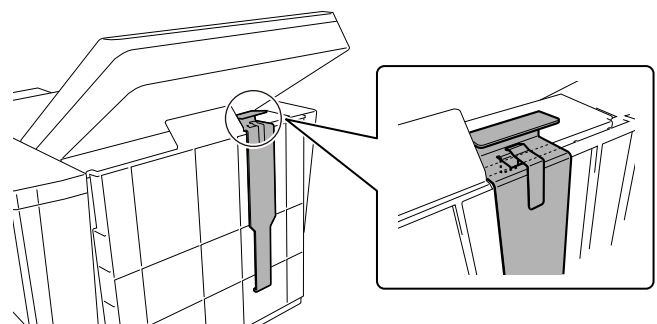
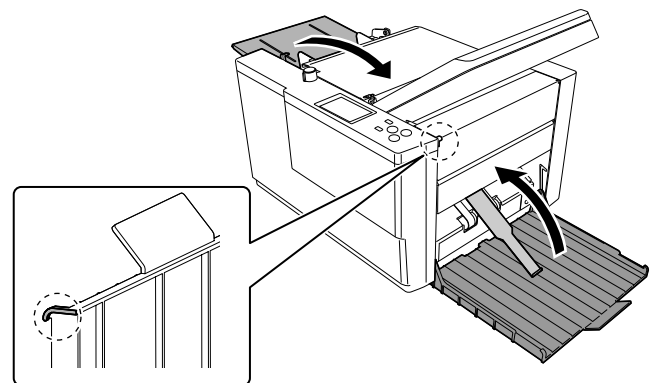



Chapter 3 Advanced Operation

1. Correcting Folding Misalignment

Folding misalignment consists of “folding misalignment along the sides of the paper” and “folding misalignment along the vertical length of the paper”. Other than this, “deformed folding” may also occur due to paper characteristics, etc.

Depending on the usage environment (temperature and humidity), paper type, thickness, paper grain direction, trimming accuracy, and printing states folding misalignment may occur.

! CAUTION	
	Do not put fingers inside during operation.
	Keep away long hair, ties, jewelry and loose clothing.
	It could cause injury.

1-1. Adjustment folding misalignment in right and left direction

When the folded paper is misaligned along the sides, correct using the skew correction knob of the paper feed tray.

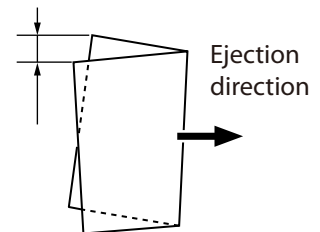

1 Check that the paper feed guides are set correctly.

Gaps between the paper and paper feed guides will cause folding misalignment along the sides to occur easily.

Proceed to step 2 if the paper feed guides are set properly.

Perform test folding after resetting the paper feed guides. Proceed to step 2 if folding misalignment occurs after setting the paper feed guides properly.

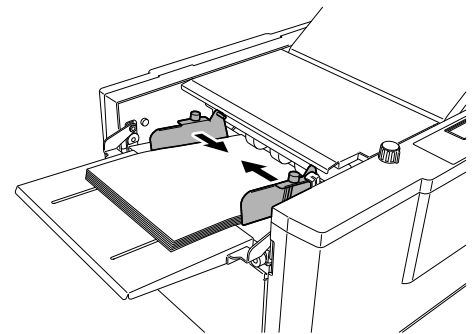

2 Remove the paper stacked on the paper feed tray.

Adjustments cannot be made effectively by adjusting folding misalignment with skew correction knob when the leading edge of paper is in contact with the guide plate.

3 Rotate the skew correction knob and adjust.

Folding misalignment A

Rotate the knob in the clockwise direction. The leading edge of paper on the right side (on the control panel side) will be fed earlier.

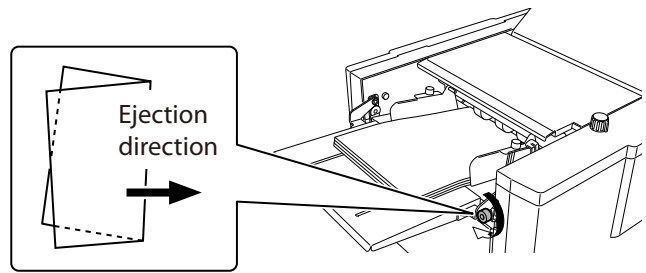

Folding misalignment B

Rotate the knob in the counterclockwise direction. The leading edge of paper on the left side (on the non-operator's side) will be fed earlier.

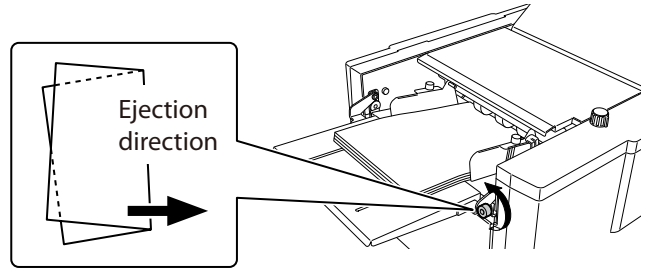

4 Stack paper on the paper feed tray.

Push in paper so that the edge of paper comes lightly in contact with the guide plate.

5 Tighten the guide fixing screw on the paper feed guide.

6 Perform test folding.

7 After completing folding operations, return the skew correction knob to the standard position.

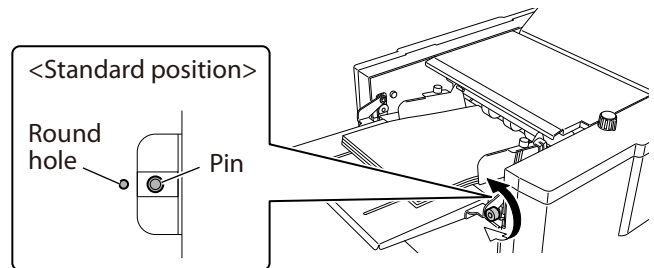

1-2. Adjustment folding misalignment in up and down direction

When the folded paper is misaligned along the vertical length, adjust the positions of the folding stopper of folding plates 1 and 2 to correct the misalignment.

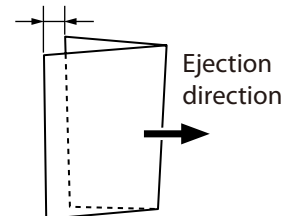

Adjustable range and correction restrictions

- Adjustable range of folding position A adjustment key/folding position B adjustment key on the [Fold Position] screen during standard folding is within ± 5.0 mm/0.20 inch.
- The positions of the folding stoppers of folding plates 1 and 2 may not be adjustable to ± 5.0 mm/0.20 inch according to the length of the paper used.
- For custom folding and [Stopper fixing mode], the folding positions are set directly according to the paper length, and the adjustable range of ± 5.0 mm/0.20 inch is not restricted.

Example: for single fold

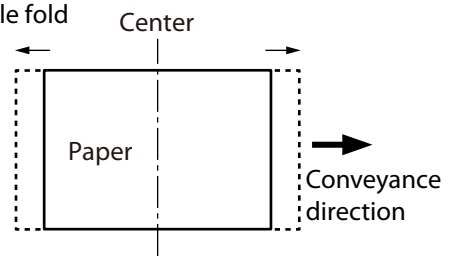

Adjustment by using the [-] key.
-5.0 mm/0.20 inch or less

Adjustment by using the [+] key.
+5.0 mm/0.20 inch or less

The restricted folding plate and adjustment details differ according to the folding mode and paper length.





Folding mode	Restricted range of paper length (*)	Restricted folding plate	Restricted adjustment key
Double fold	182.0 to 203.9 mm/7.17 to 8.03 inches	Folding plate 2	◀ key
Irregular accordion fold-out	182.0 to 186.7 mm/7.17 to 7.35 inches	Folding plate 1	▶ key
	182.0 to 199.9 mm/7.17 to 7.87 inches	Folding plate 2	▶ key
Letter fold	141.0 to 150.5 mm/5.55 to 5.93 inches	Folding plate 2	◀ key
Accordion-fold	141.0 to 151.1 mm/5.55 to 5.95 inches	Folding plate 2	▶ key
Gate fold	425.1 to 432 mm/16.74 to 17.01 inches	Folding plate 1	◀ key
	422.8 to 432 mm/16.65 to 17.01 inches	Folding plate 2	▶ key

(*) Range of paper length which cannot be corrected to ± 5.0 mm/0.20 inch. The adjustment value differs according to the paper length.

Adjustment folding misalignment along vertical length of paper by folding mode

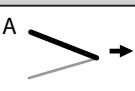
For misalignment along the vertical length of standard folding, use the folding position A adjustment key/ folding position B adjustment key on the [Fold Position] screen to adjust.

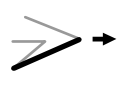
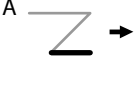
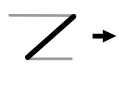
☞ "Adjustment method" (p.45)

Folding plate 1				Folding plate 2			
Folding mode		State of folded plane A	Folding A position adjustment key	Folding mode		State of folded plane B	Folding B position adjustment key
Single fold	A 	A is long	▶ key	Single fold	Folding plate 2 is not used.		
		A is short	◀ key				
Double fold	A 	A is long	▶ key	Double fold	B 	B is long	◀ key
		A is short	◀ key			B is short	▶ key
Irregular accordion fold-out	A 	A is long	▶ key	Irregular accordion fold-out	B 	B is long	▶ key
		A is short	◀ key			B is short	◀ key
Letter fold	A 	A is long	▶ key	Letter fold	B 	B is long	◀ key
		A is short	◀ key			B is short	▶ key

Folding plate 1				Folding plate 2			
Folding mode		State of folded plane A	Folding A position adjustment key	Folding mode		State of folded plane B	Folding B position adjustment key
Accordion fold	A	A is long	▶ key	Accordion fold	B	B is long	▶ key
		A is short	◀ key			B is short	◀ key
Gate fold	A	A is long	▶ key	Gate fold	B	B is long	◀ key
		A is short	◀ key			B is short	▶ key

Adjustment method

Adjust the position of the folding stopper using the folding position A adjustment key/folding position B adjustment key on the [Fold Position] screen.

Touch the key on the [Ready] screen.

The [Fold Position] screen is displayed.

Folding stopper of folding plate 1:

- To move in the direction of [a]
Touch the ▶ key of the folding A position adjustment key.
- To move in the direction of [b]
Touch the ◀ key of the folding A position adjustment key.

Folding stopper of folding plate 2:

- To move in the direction of [c]
Touch the ◀ key of the folding B position adjustment key.
- To move in the direction of [d]
Touch the ▶ key of the folding B position adjustment key.

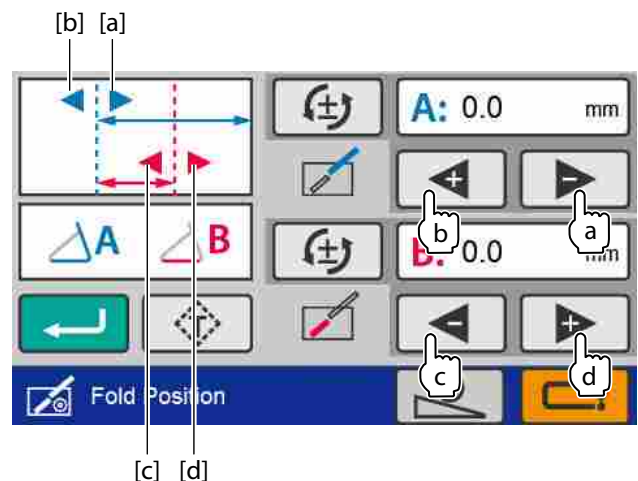

- The folding stopper moves 0.1 mm/0.004 inch each time you press the adjustment key.
Also, when you press and hold the position adjustment key, the value continues to change within the setting range of the folding stopper.
- When you input the value manually, touch [A:x.x mm] or [B:x.x mm]. The numeric keypad is displayed.
- The changed value is cleared when power is turned off. To save the changed value, see "Saving the adjusted value" (p.45).

Saving the adjusted value

If you save the adjustment value for the next time you use the same paper, you can perform folding operation under the same adjustment value as the one that is saved at this time.

- For standard folding of standard paper, touch the key. —> Press and hold the key to save the adjustment value.
- For standard folding or custom folding of non-standard paper, touch the key. —> Touch the key. —> Select and save the saved data number of custom folding.
 "3. Custom Folding" (p.47)

1-3. Deformed folding

The paper may not be folded properly due to the characteristics of paper. In such cases, check the following points.

- Do not use paper outside the specifications.
Particularly, deformed folding occurs frequently in the use of thin, flimsy paper not appropriate.
- Lower the processing speed when deformed folding occurs for thin and flimsy paper.
☞ "8-2. Thin paper mode" (p.61)
- Separate paper well prior to stacking.
☞ Chapter 1 "8-1. Paper used" (p.30)
- Stack paper on the paper feed tray after aligning well, and set the paper feed guides at the correct positions. Also tighten the fixing screws of the paper feed guides firmly.
☞ Chapter 2 "2-2. Stacking paper" (p.34)

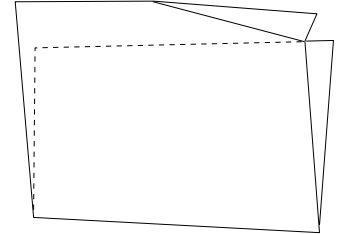

2. Standard Folding of Non-Standard Paper

Standard folding of non-standard paper is a method to perform paper folding by saving paper lengths other than standard paper and selecting the folding mode of standard folding.

Paper other than the six standard paper is called non-standard paper. (The A6, A7, or B7 paper can be used as non-standard paper.) (five standard paper sizes For NA)

The foldable sizes are as follows. (width x length)

Maximum : 311 x 457.2 mm/12.24 x 18.00 inches

Minimum : 74 x 105.0 mm/2.91 x 4.13 inches

Depending on the paper length, the following folding modes are limited.

Double fold, irregular accordion fold-out:
182.0 to 457.2 mm/7.17 to 18.00 inches

Letter fold, Accordion-fold:
141.0 to 457.2 mm/5.55 to 18.00 inches

Gate fold:
128.0 to 432.0 mm/5.04 to 17.00 inches

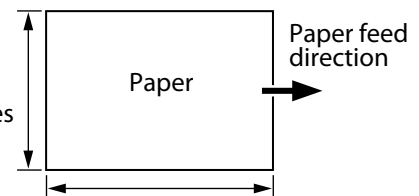

Width :
74 to 311 mm/
2.91 to 12.24 inches



Length : 105.0 to 457.2 mm/
4.13 to 18.00 inches

- ▼ • **Standard paper which is stacked on the paper feed tray in the long edge feeding direction is considered non-standard paper.**
- **The paper sizes which can be used may vary with the paper type, thickness, and printing state.**

Example: When performing letter fold on 300.0 mm length paper

- 1** Touch the  key on the [Ready] screen —> Touch [Standard Fold for Non-Standard Size].
- 2** Using the numeric keypad, enter the paper length [300] —> Touch the  key.

- 3** Touch the  key.
Return to the [Ready] screen.

3. Custom Folding

- Custom folding is an operation method to fold paper at any position by specifying the folding stopper positions (folding position) of the folding plates 1 and 2.
- The foldable sizes are as follows.
(width x length)
Maximum: 311 x 457.2 mm/12.24 x 18.00 inches
Minimum: 74 x 105.0 mm/2.91 x 4.13 inches

<Standard single fold>

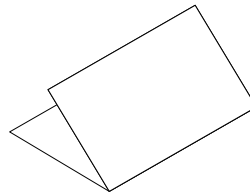

<Example of custom single fold>

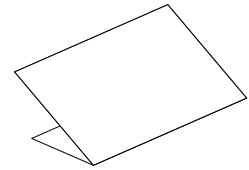

▼ The paper sizes which can be used may vary with the paper type, thickness, and printing state.

- The length of the folded plane (see figure to the right) which can be folded by folding plates 1 and 2 is restricted.
Folding plate 1: 42.0 to 325.0 mm/1.65 to 12.80 inches
Folding plate 2: 0.0 (*)/47.0 to 217.0 mm /0.0 (*)/1.85 to 8.54 inches
(*)As folding plate 2 is not used in single folding, it is 0 mm/0 inches.

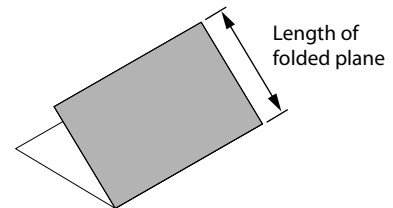

▼ Incorrectly measuring the paper length or setting the folding stopper position can cause paper jamming inside the folding plate.

3-1. Operation

As an example of accordion-fold, operation procedures for custom folding are described with the following setting.

Paper size: A4 (210 x 297.0 mm/8.27 x 11.69 inches)
Fold1: 85.0 mm/3.35 inches (length A)
Fold2: 95.0 mm/3.74 inches (length B)

- 1 Prepare a folding sample manually using the paper to be folded.**
- 2 Measure the length of the folding position of the sample.**

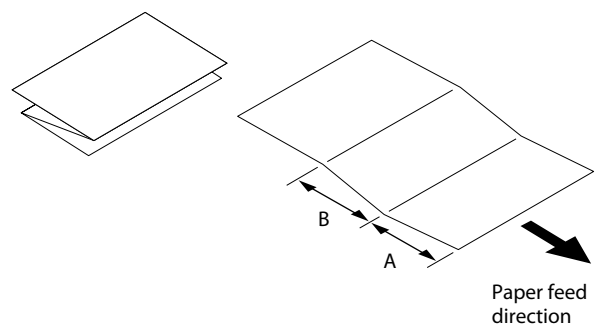

3 Touch the  key on the [Ready] screen.

The [Paper Length] input screen is displayed.



In stopper fixed mode or manual feed mode (*), the  key is not displayed.
(*)Option

4 Touch the  key.

For the DF-999/DF-999A, the [Create New Custom Fold] screen is displayed. Proceed to step 6.

For the DF-990/DF-990A, the [Size] screen is displayed. Proceed to step 5.

If the  key cannot be operated, the standard paper size is not detected. Check the position of the paper feed guide.

If the  key cannot be operated even after that, using the numeric keypad, enter the paper length on the [Paper Length] input screen and then touch the  key.

5 Touch the [A4].

The [Create New Custom Fold] screen is displayed.

6 Touch the  key → Touch the  key.

Return to the [Create New Custom Fold] screen.

7 Touch the [A: xxxx.x mm] key → Using the numeric keypad, enter the folding A length [85] → Touch the  key.

Return to the [Create New Custom Fold] screen.

8 Touch the [B: xxxx.x mm] key → Using the numeric keypad, enter the folding A length [95] → Touch the  key.

Return to the [Create New Custom Fold] screen.

9 To save the input value, touch the  key. To continue working without saving, touch the  key.

When you touch the  key, [Save] screen is displayed. Proceed to step 10.

When you touch the  key, the display returns to the [Ready] screen with the input value reflected.

- The input value is reflected but not saved.
- When the power is turned off without performing save operation, the input number is cleared.
You can save the data before turning off the power.
 "3-6. Directly saving folding value under processing" (p.50)
- When the stacker roller position is changed while in custom fold, the changed value is saved automatically.

10 Touch the  key.

The input value is saved, and the display returns to the [Ready] screen with the input value reflected.

The procedures taken after that will be the same as the steps 8 to 13 in Chapter 2 “3.Standard Folding of Standard Paper” (p.36)







The stacker roller position moves automatically according to the paper set.

Adjust the stacker roller position, if the paper flaps or misaligns at the time of ejection, or paper jam occurs in the paper ejecting section.



☞ “6-2. Adjusting stacker roller position” (p.59)

3-2. Editing saved data

When the custom fold data that you want to edit is opened



- 1** Touch the  key on the top screen.
The [Paper Length] input screen is displayed.
- 2** Touch the  key.
When you change the paper length, input the paper length with the numeric keypad, and touch the  key.
- 3** Touch [A:xxxx.x mm] or [B:xxxx.x mm] for the folding that you want to fine-adjust. —> Input the value with the numeric keypad. —> Touch the  key.
Return to the [Ready] screen.
- 4** Perform step 9 to 10 in “3-1. Operation” (p.47).

When the custom fold data that you want to edit is not opened

- 1** Touch the  key—> Touch the [Custom Fold].
The [Custom Fold] screen is displayed.
- 2** Select the number that you want to save. —> Touch the  key.
The [Edit] screen is displayed.
- 3** Perform step 3 to 4 in “When the custom fold data that you want to edit is opened”.





3-3. Using saved data

Example: When using saved data number [06]

- 1** Touch the  key on the [Ready] screen —> Touch [Custom Fold].
The [Custom Fold] saved data selection screen is displayed.
- 2** Touch the  key —> Touch [06] of custom fold data —> Touch the  key.
The saved data number [06] is saved, and the display returns to the [Ready] screen.

3-4. Locking saved data

To prevent accidentally deleting data you want to be saved, you can lock saved data and prevent the numerical value from being changed.

- 1 Touch the  key on the [Ready] screen → Touch [Custom Fold].**
The [Custom Fold] saved data selection screen is displayed.
- 2 Select the number of the saved data you want to lock → Touch the  key.**
 is displayed on the right of the number of the saved data.
Press and hold the  key to release the lock.
- 3 Press and hold the  key.**
Return to the [Ready] screen.







Even if paper folding is being processed using the locked data, the folding position can be fine-adjusted. However, when you want to save the fine-adjusted value, release the lock.

 "3-2. Editing saved data" (p.49)



3-5. Deleting saved data

Locked saved data cannot be deleted. To delete saved data, unlock the data.

- 1 Touch the  key on the [Ready] screen → Touch [Custom Fold].**
The [Custom Fold] saved data selection screen is displayed.
- 2 Touch the  key.**
The [Save] screen is displayed.
- 3 Select the number of the saved data you want to delete → Press and hold the  key.**
Saved data is deleted.
- 4 Press and hold the  key.**
Return to the [Ready] screen.

3-6. Directly saving folding value under processing

You can save the folding status for cases such as when you want to continue operation using the same setting contents during paper folding processing. To save, perform test folding or folding processing to check folding misalignment, carry out the fine adjustments and then save.

- 1 Touch the  key on the [Ready] screen.**
The [Save] screen is displayed.
- 2 Select the number of the data you want to save → Touch the  key.**
The input value is saved and the display returns to the [Ready] screen.

4. Cross Fold

Cross fold is folding single-folded paper another time as shown in the figure. The maximum paper thickness is fine quality paper 104.7 g/m²/71.20 lbs.

- ! • **Paper Σ dent and folding misalignment in both directions may increase or paper may be fed unstably depending on the following conditions. However, it is not a malfunction.**
- **The folded line of single-folded paper is not folded properly.**
 - **Usage environment (temperature and humidity)**
 - **Paper thickness, paper size, paper type, or paper grain direction, etc.**
 - **Double-feed detection does not operate when cross fold is performed. Select the setting [OFF]. (DF-999/DF-999A)**

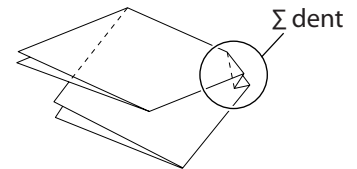

! CAUTION



Do not put fingers inside during operation.



Keep away long hair, ties, jewelry and loose clothing.



It could cause injury.

4-1. Cross fold of standard paper

The following describes the cross fold of standard paper, taking cross single folding shown in the figure as an example.

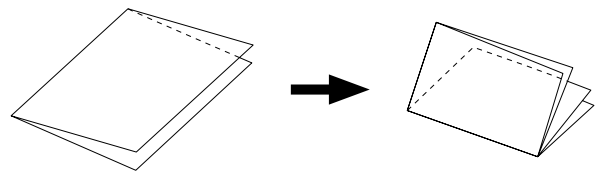

4-1-1. Stacking paper

1 Single fold standard paper according to the procedure of Chapter 2 “3. Standard Folding of Standard Paper” (p.36).

2 Press the folded line of single-folded paper with the fingertip.

The paper feeding state will be unstable or paper dent may be caused if the folded line of folded paper is not folded firmly.

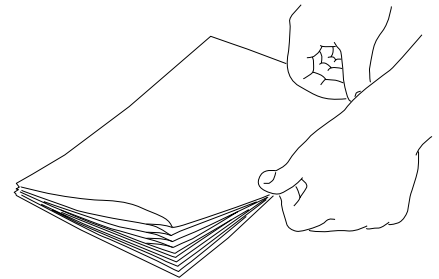

3 Raise the paper set lever. (DF-990/DF-990A)

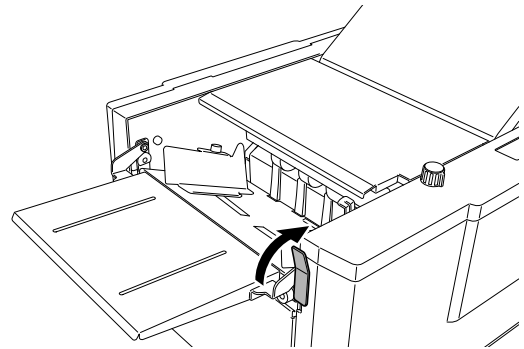

4 Loosen the guide fixing screw.

5 Stack the single-folded paper on the paper feed tray with the folded line toward the non-operator's side.

The stacking amount is equivalent to about half (25 mm/0.98 inch) of the height of the paper feed guide on the folding side.

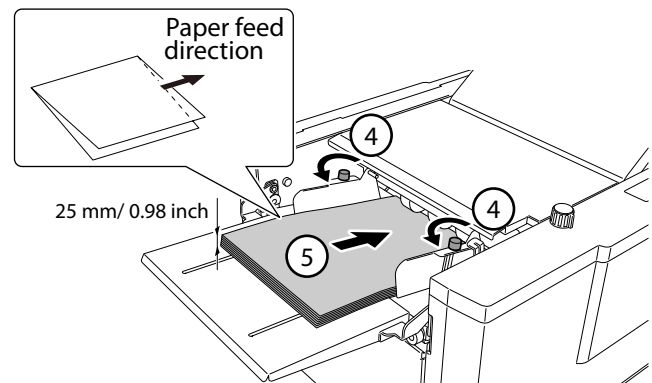

6 Attach the paper feed guide lightly to the side of the paper and tighten the fixing screws.

7 Lower the paper set lever. (DF-990/DF-990A)

4-1-2. Adjustment of the parts

1 Turn off the power switch.



2 Disconnect the power plug from the outlet.



3 Take the T-handle hexagonal wrench.

4 Open the top cover.

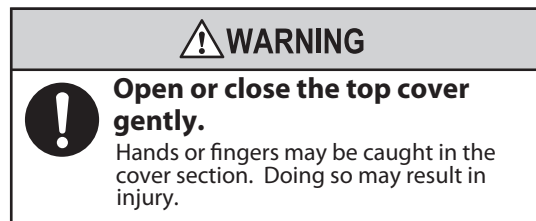

5 Loosen the screw of the auxiliary paper feed ring (for moving) using the T-handle hexagonal wrench, accessory part.

! Do not use the T-handle hexagonal wrench for a purpose other than handling the auxiliary paper feed ring as instructed in this manual.

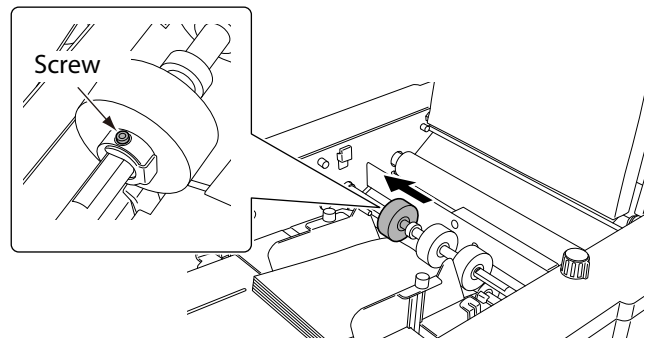

WARNING



Do not disassemble the product more than needs.

Fire, electrification, injury, malfunction, or breakdown may be caused by disassembling the parts which are not specified in this manual.

6 Move the auxiliary paper feed ring.

Move the auxiliary paper feed ring so that it will be on the folding line of the paper.

7 Tighten the screw loosened.

Store the T-handle hexagonal wrench in the original position after adjustment the auxiliary paper feed ring.

8 Set the separating pressure adjustment dial to [0].

⚠ **Set the paper separating pressure as low as possible. Setting it high will cause the single-folded paper to open during paper feed, resulting in paper feed error.**

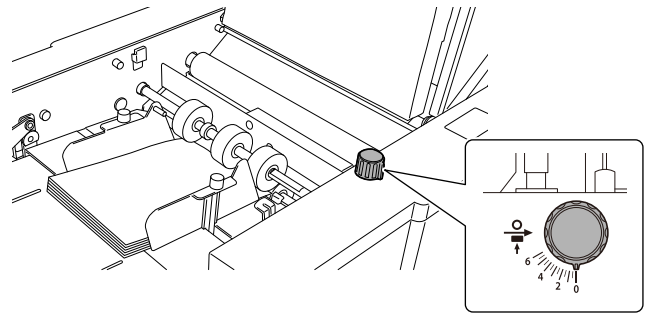

9 Set the feeding pressure adjustment lever to [3].

Set the paper feed pressure within the range of scale [3] to [5].

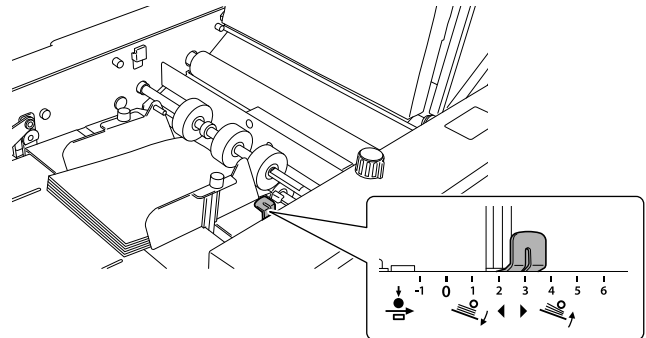

10 Take out the cross fold lever.

11 Attach the cross fold lever to the paper feed guide on the left side.

- Attach the cross fold lever so that the weight roller on the leading edge of the cross fold lever will be on the folding line.
- Raise the cross fold lever in the direction of an arrow when stacking paper in addition.

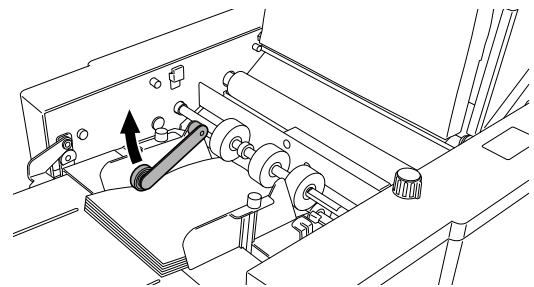

12 Close the top cover.

4-1-3. Operation procedures

1 Turn on the power.

2 Touch the [Home] key on the [Ready] screen → Touch the [Power] key.
Return to the [Ready] screen.

3 Press the [Test] key to execute test folding.

4 Check the finishing.

Store the cross fold lever at the original position after cross fold operation.

- ▼ **Be sure to store the cross fold lever at the specified place and in the specified direction. By moving during operation of this machine the folding roller may be damaged, resulting in malfunction.**

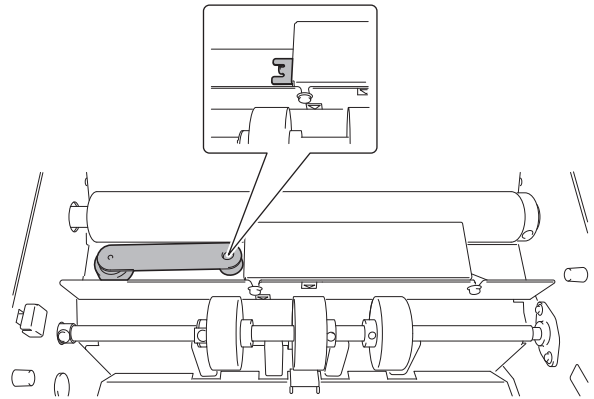

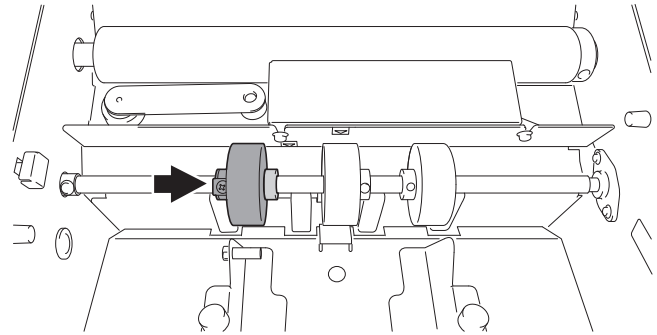

- 5 Turn off the power.**
- 6 Disconnect the power plug from the outlet.**
- 7 Loosen the screw on the auxiliary paper feed ring (for moving) with the T-handle hexagonal wrench.**
- 8 Strike the auxiliary paper feed ring at the collar.**
- 9 Tighten the screw loosened.**

- ▼ **Do not use the T-handle hexagonal wrench for a purpose other than handling the auxiliary paper feed ring as instructed in this manual.**



4-2. Cross fold of non-standard paper

- 1 Single fold non-standard paper according to the procedure of "2.Standard Folding of Non-Standard Paper" (p.46).**
- 2 Measure the length of the finished single folded paper.**
- 3 Touch the  key on the [Ready] screen → Touch [Standard Fold for Non-Standard Size].**
- 4 Using the numeric keypad, enter the paper length → Touch the  key.**
- 5 Touch the  key.**
Return to the [Ready] screen.
- 6 Perform step 2 of "4-1-1. Stacking paper" to "4-1-3. Operation procedures" of "4-1. Cross fold of standard paper" (p.51).**

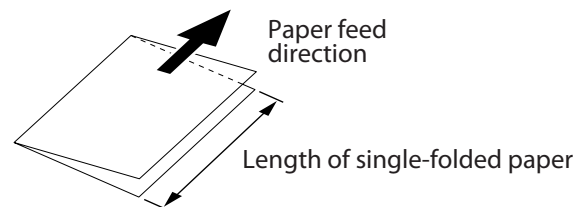

4-3. Cross fold paper at desired folding position

Cross folding is a method to cross fold standard paper and non-standard paper at the desired folding position. Standard paper is handled the same as non-standard paper and is operated in a method that saves the folding position on the custom fold.

- 1** Save the custom fold using the procedure in “3. Custom Folding” (p.47).
- 2** Single-fold the paper in the custom folding mode.
- 3** Again, save the custom fold of the single folded paper using the procedure in “3. Custom Folding” (p.47).
- 4** Take procedures for “4-1-1. Stacking paper” step 2 to “4-1-3. Operation procedures” of “4-1. Cross fold of standard paper” (p.51).

5. Using Special Paper

⚠ CAUTION





Do not put fingers inside during operation.

Keep away long hair, ties, jewelry and loose clothing.

It could cause injury.

5-1. Art paper, coated paper

Art paper and coated paper often stick to each other due to the printing ink and become difficult to separate, resulting in double-feed. When using these types of paper, follow the procedure below.

- 1** **Separate the paper well.**
 Chapter 1”8-1. Paper used” (p.30)
 Some of recycled art or coated paper may be unsuitable for folding due to weak stiffness.
- 2** **Align the paper.**
- 3** **Stack the paper on the paper feed tray.**
- 4** **Attach the paper feed guide.**

⚠ Do not stack too many sheets of paper on the paper feed tray. If too many sheets are stacked, the paper will stick on each other from its height and become difficult to separate, resulting in double-feed. The amount of stacked sheets should be about half the weight of the paper feed guide (approx. 25 mm/0.98 inch).

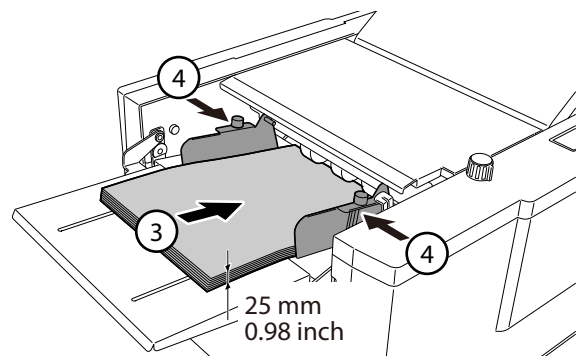

5 Set the feeding pressure adjustment lever to [3].

- Set the paper feed pressure within the [3] to [5] range on the scale.
- When paper mis-feed occurs, increase the paper feed pressure to [4] or [5].

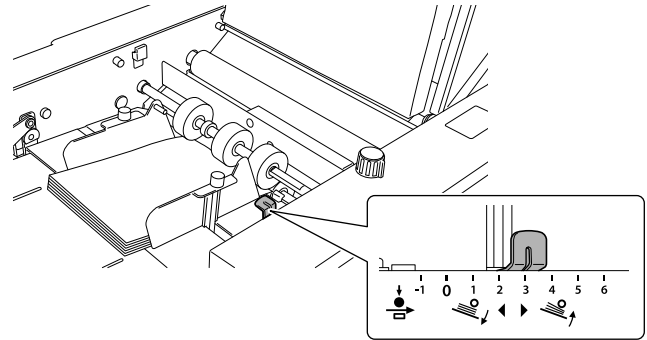

6 Set the separating pressure adjustment dial to [2.5].

If double-feed occurs, increase the separating pressure by [0.5] at a time.

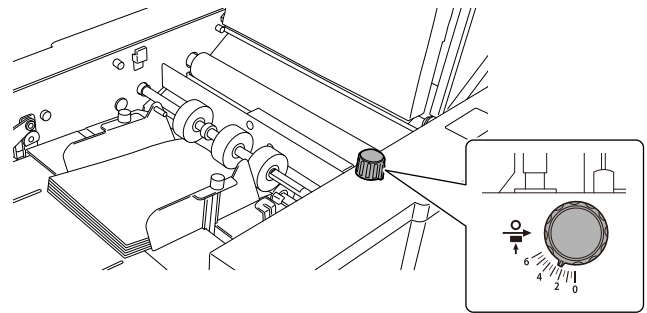

7 Press the key to test fold.

8 Check the finish.

If abnormal folding occurs, decrease the processing speed.

- ▼ **After completing folding operation of art paper or coated paper, return the paper feeding pressure and separating pressure each to [0]. If fine quality paper is used with the paper feed pressure and separating pressure set to the values for art paper and coated paper, double-feed may occur, or leading edge of paper may be damaged.**

5-2. Rough paper, recycled paper

Some recycled paper may be thin, flimsy and easy to curl when copied, and therefore inappropriate for folding. When folding such paper, pay attention to the following points.

- Separate the paper well prior to stacking on the paper feed tray.
- Set the processing speed as low as possible.
If set to high, wrinkles or deformed folding will result.
- Set the paper feed pressure as low as possible.
If set to high, double-feed will result.
- Set the paper separating pressure as low as possible.
If set to high, the center of the lead edge of the paper may be scratched or turned over.

5-3. B7, A7, A6 size paper (For EU)

B7, A7, A6 size paper (fed by short edge feeding) can be folded in the following conditions.

However, B7, A7, or A6 paper is regarded as non-standard paper, and the paper length should be registered, referring to "2.Standard Folding of Non-Standard Paper" (p.46).

- The paper feed direction is only in the vertical direction.
- Folding modes that can be selected:
 - B7: Single fold, Gate fold
 - A7: Single fold
 - A6: Single fold, Letter fold, Accordion-fold, Gate foldThe keys of folding modes that cannot be selected are grayed and cannot be operated.
- Folding style is limited depending on the paper quality or paper size.
☞ Chapter 7 "1. Specifications" (p.93)

▼ **If small and light paper is used, too fast processing speed will result in stream-feed (continuous feed). Decrease the processing speed as slow as possible.**

 When mis-feed or double-feed occurs even though the feeding pressure and separating pressure are set to the set value, adjust the feeding pressure and separating pressure.

☞ Chapter 2 "3. Standard Folding of Standard Paper" (p.36)

6. Stacker Roller

6-1. Changing stacker roller height

Some thick and stiff paper may not be ejected smoothly because the paper may open after folding. Change the stacker roller height and widen the space for the paper to pass in ejection.

1 Remove the auxiliary paper ejection guide and paper support guide.

2 Lift the stacker roller and hold it with hand to move to the [A] position shown in the figure.

▼ **After completing folding operations, be sure to return the stacker roller to the standard position. Leaving it in the raised state will result in poor alignment of ejected paper.**

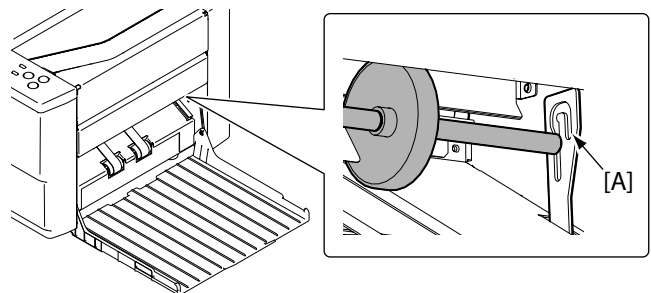

6-2. Adjusting stacker roller position

During cross folding or when folding thick paper, adjust the position of the stacker roller in cases when the paper is opened when ejected causing misalignment or when a paper jam occurs in the paper ejecting section.

! Do not move the stacker roller forcibly back and forth by hand. The machine may be broken by doing so.

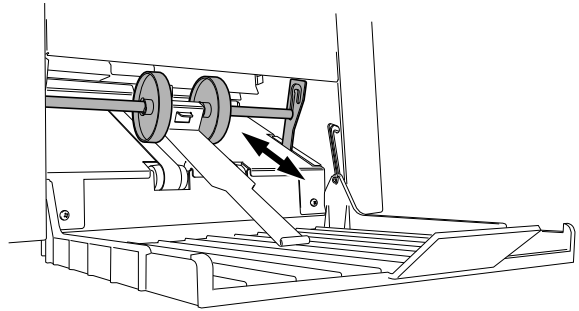

Guide for the setting position of stacker roller

Settings	Applicable standard paper size and folding mode			
	For EU		For NA	
1	B5	Double fold	STMT, INV	Double fold, Letter fold, Accordion-fold
	A5	Double fold, Letter fold, Accordion-fold		
	B6	Double fold, Letter fold, Accordion-fold, Gate fold		
3	A4	Double fold	LTR	Double fold
	B5	Accordion-fold, Gate fold		
	A5	Gate fold		
5	A3, B4	Double fold	STMT, INV	Single fold, Irregular accordion fold-out, Gate fold
	A4	Letter fold, Accordion-fold	LTR	Letter fold, Accordion-fold
	B5	Letter fold	LGL, LGR	Double fold
	A5, B6	Single fold, Irregular accordion fold-out		
7	A4	Gate fold		
8			LTR	Gate fold
9	B4	Letter fold, Accordion-fold	LGL	Letter fold, Accordion-fold
	B5	Single fold, Irregular accordion fold-out		
11	A3	Letter fold, Accordion-fold	LTR	Single fold, Irregular accordion fold-out
	A4	Single fold, Irregular accordion fold-out	LGR	Letter fold, Accordion-fold
15	A3, B4	Single fold, Irregular accordion fold-out, Gate fold	LGL, LGR	Single fold, Irregular accordion fold-out, Gate fold

When sheets of paper folded in the gate fold mode unfold and a sheet processed later slips into the one processed before:

Depending on the type and size of paper, the adjustable range in the gate fold mode is limited. Be sure to decrease the setting values one scale at a time in this mode and check the results.

1 Touch the  key on the [Ready] screen.

The [Fold Position] screen is displayed.

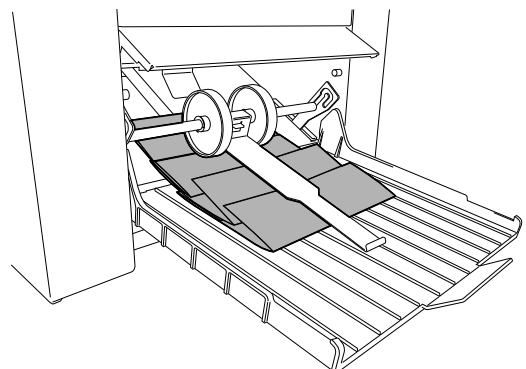

2 Touch the  key.

The [Stacker Roller] screen is displayed.

3 Using the [+]/[-] keys, adjust the position of the stacker roller.

- The smaller the value becomes, the more the position of the stacker roller moves to the internal side of the machine. The higher the value, the more it moves to the outer side of the machine.
- [0] is used when a paper jam occurs during cross folding. When value is set to [0], the processing speed becomes slow.

4 Touch the  key.

Paper for test folding is not counted as the number of processed sheets.

5 Touch the  key.

Return to the [Fold Position] screen.

6 Touch the  key.

Return to the [Ready] screen.

When the paper size or folding mode is changed, the changed value is cleared.

When the paper size is changed by automatic paper size detection, the value is not cleared. (DF-999/DF-999A)

7. Stacking the Folded Paper

The angle of the paper receiving tray of this machine can be changed. If the angle is changed, the folded paper can be stacked in the following two ways according to the purpose.

Straight stacking

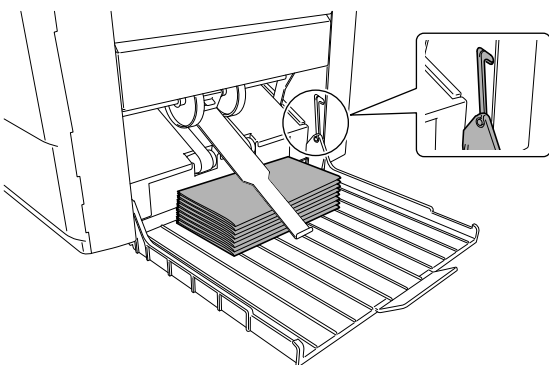

Diagonally stacking

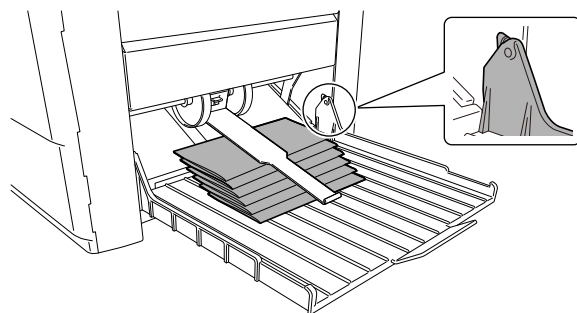

If you use the paper support guide when diagonally stacking paper satisfying the following conditions, the paper will be ejected and stacked neatly.

- Paper size: A4/LT
- Thickness of paper: Fine quality paper 64 g/m²/43.52 lbs, 81.4 g/m²/55.35 lbs
- Folding mode: Letter fold, Accordion fold

8. Function Setting

Function setting can be performed for shortening the operation procedure or adjustment according to the paper used based on the purpose of the user.

8-1. Thick paper mode



Set this mode when double folding B4 or larger, thick (104.7 g/m²/71.20 lbs or more) fine quality paper. Use only thick paper in this mode. Use of this mode may result in unstable paper feed, and make parts wear down quickly.

Touch the  key on the [Ready] screen —> Change the processing speed to .

Touch the  key to clear the thick paper mode.

8-2. Thin paper mode

Use the thin paper mode when handling thin and flimsy paper such as rough paper and recycled paper. Do not use for the paper other than thin type. When using this mode for the paper type other than thin paper, paper jam may occur.

Touch the  key on the top screen —> Change the processing speed to .

Touch the  key to clear the thin paper mode.

8-3. Interval function



Interval (suspension) function is a function to specify the number of sheets to be folded and suspend folded paper by interrupting paper folding operation for a certain period of time.

Take out ejected paper during interruption, and another operation after paper folding such as distribution or enclosure can be prepared.

Touch the  key on the [Ready] screen —> Touch the  key —> Touch the [Interval].

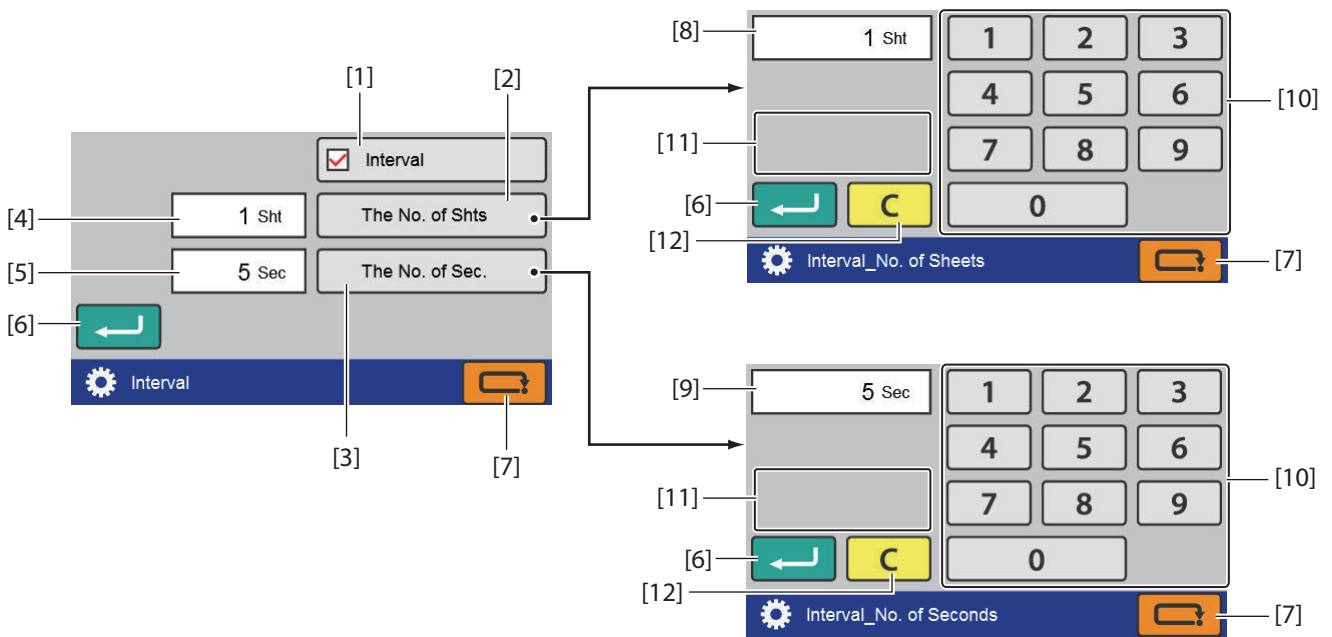
The [Interval] screen is displayed.



No.	Name	Function	Default value
[1]	Interval	Sets on/off of the interval function.	-
[2]	No. of Sheet	The [Interval_No. of Sheets] screen is displayed. When the interval setting is turned off, the key is grayed out and cannot be operated. Setting range: 1 to 999 (sheets)	1
[3]	The No. of Sec.	The [Interval_No. of Seconds] screen is displayed. When the interval setting is turned off, the key is grayed out and cannot be operated. Setting range: 3 to 30 (seconds)	5
[4]	Interval_No. of Sheets setting value	Displays the currently set interval sheets number.	-
[5]	Interval_No. of Seconds setting value	Displays the currently set interval time.	-
[6]	 (Return) key	[Interval] screen Saves the on/off setting of the interval and returns to the [Function Settings] screen. [Interval_No. of Sheets] screen/[Interval_No. of Seconds] screen Saves the input value and returns to the [Interval] screen.	-
[7]	 (Cancel) key	[Interval] screen Returns to the [Function Settings] screen without saving the input content. [Interval_No. of Sheets] screen/[Interval_No. of Seconds] screen Returns to the [Interval] screen without saving the input value. Press and hold to return to the [Ready] screen.	-
[8]	Interval sheet number input value	Displays the input value.	-
[9]	Interval time input value		-
[10]	Numeric keypad	Inputs the value.	-

No.	Name	Function	Default value
[11]	Input range display.	Displayed when trying to input a value outside the input range.	–
[12]	 (Clear) key	Sets the input value to "0".	–

After setting, an icon () is displayed on the touch panel display section.

8-4. Double-feed detection

Double-feed detection refers to a function that reads the thickness of paper on test folding and detects when more than one sheet of paper is fed into the machine at a time.

When the ultrasonic sensor is set, there is no need to perform test folding.

Touch the  key on the top screen → Touch the  key → Touch the [D-Feed Detect].



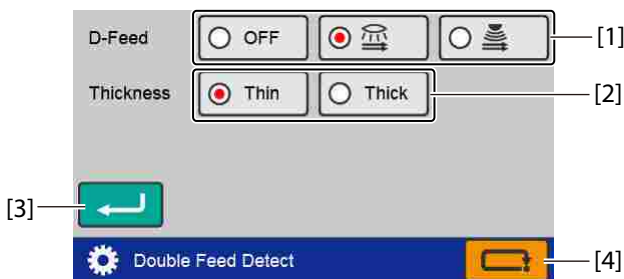

The [Double Feed Detect] screen is displayed.

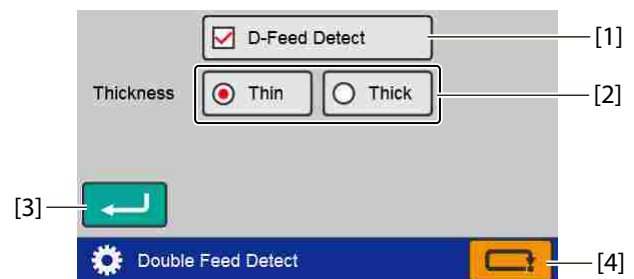

When the DF ULTRASONIC SENSOR KIT is registered



When the DF ULTRASONIC SENSOR KIT is not registered





No.	Name	Function	Default value
[1]	D-Feed Detect	Sets whether to enable double feed detection. When the DF ULTRASONIC SENSOR KIT is not registered, on/off can be changed with the checkbox. <input type="radio"/> OFF Disables double feed detection. <input checked="" type="radio"/>  Enables the optical sensor. <input type="radio"/>  Enables the ultrasonic sensor. (*)	–
[2]	Thickness	When the optical sensor is set for double feed detection, set the thickness of the paper. When the ultrasonic sensor is selected, the key is grayed out and cannot be operated.	Thin
[3]	 (Return) key	Saves the double feed detection setting and returns to the [Function Settings] screen.	–
[4]	 (Cancel) key	Returns to the [Function Settings] screen without saving the input content. Press and hold to return to the [Ready] screen.	–

(*) Displayed only when the DF ULTRASONIC SENSOR KIT is registered as an optional item. (DF-999/DF-999A)

After setting, an icon is displayed on the touch panel display section.

 Chapter 1 "6-1-2. Touch panel operation section" (p.16)

When the optical sensor is enabled

- Set the paper [Thickness] to [Thin], when normal operation is performed.
If a double-feed is wrongly detected though the paper thickness is set to [Thin] and no double-feed occurs in test folding or normal operation, set to [Thick].
- Perform the test folding before you start processing the paper folding.
The machine will not start if test folding is not performed even when the  key is pressed.
When the test folding is performed, the icon changes from  to .
- When paper shorter than 148.0 mm/5.83 inches is used, the double-feed detection is not performed.
At this time, there is no need to perform test folding.
When paper shorter than 148.0 mm/5.83 inches is used, the icon becomes .
- The data on paper thickness read by test folding will be cleared by changing the [Thickness] in the double-feed detection setting. Test fold again when the setting is changed.



- **Be sure to perform test folding every time printing materials are changed to different ones even if the quality and thickness of paper used are the same. Double-feed may not be detected correctly if processing is started without test folding.**
 - **Double-feed detection may not work properly if printing on paper is uneven or paper is misaligned.**
 - **Repeat test folding if double-feed occurs on test folding after double-feed detection is set to on. Double-feed will not be detected correctly if paper is processed with the same settings as when double-feed is detected on test folding.**
-

When mis-detection occurs

Double-feed or miss-feed may sometimes be detected although the paper is fed normally.

- If false double-feed detection occurs when paper thickness is set to [Thin], repeat test folding after setting paper thickness to [Thick].
If double-feed is detected mistakenly after selecting [Thick], double-feed detection function cannot be used. Set the double-feed detection to [OFF].
- If false miss-feeding detection occurs when paper thickness is set to [Thick], repeat test folding after setting paper thickness to [Thin].
If mis-feed is detected mistakenly after selecting [Thin], double-feed detection function cannot be used. Set the double-feed detection to [OFF].

8-5. Detection





If [Paper Empty] is displayed even though paper is stacked in the paper feed tray, turn off paper detection. This setting turns back on when the power is turned off.

If a detection error persists even after performing cleaning of the sensor, contact your dealer.

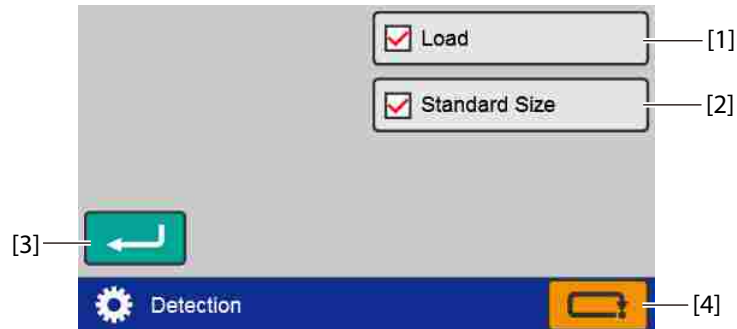
Touch the  key on the [Ready] screen → Touch the  key → Touch the [Detection].

The [Detection] screen is displayed.



No.	Name	Function	Default value
[1]	Load	Sets on/off of paper stack detection of the paper feed tray. When the paper stack detection is turned off, the paper feed tray descends after the machine stops. Touch the  key or the  key to raise the paper feed tray.	On
[2]	Standard Size	Sets on/off of automatic standard size detection. (DF-999/DF-999A) When automatic detection is turned off, you must select the paper size manually.	On
[3]	 (Return) key	Saves the detection function setting and returns to the [Function Settings] screen.	-
[4]	 (Cancel) key	Returns to the [Function Settings] screen without saving the input content. Press and hold to return to the top screen.	-

8-6. Initial

Set the setting content of the following functions when the power is turned on.

- [Oper Mode]
- [D-Feed Detect]
- [Interval]
- Processing speed
- Paper size (DF-990/DF-990A only)

Touch the  key on the top screen → Touch the  key → Touch the [When Turned On].



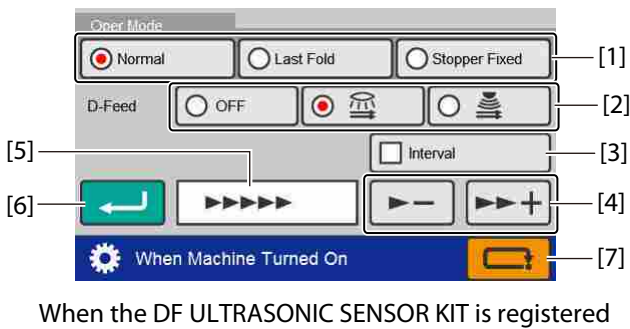

The [When Turned On] screen is displayed.

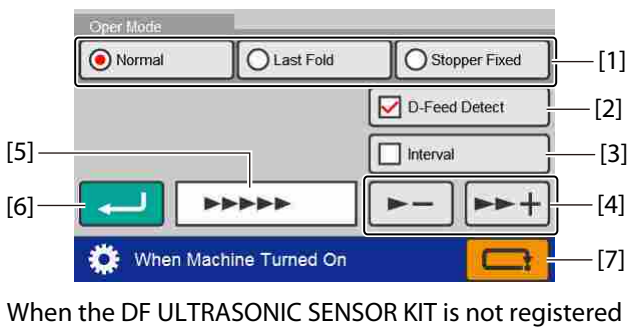
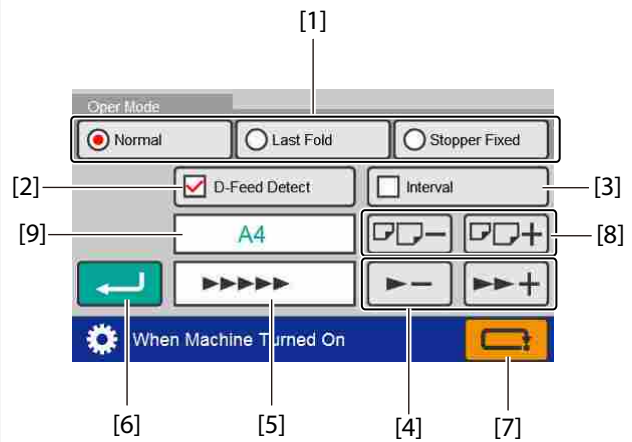

DF-999/DF-999A



DF-990/DF-990A



No.	Name	Function	Default value
[1]	Oper Mode	<p>Set the movement of the folding stopper for folding plate 1 and 2.</p> <p>[Normal]: When the power is turned on, the machine starts up in the normal setting state.</p> <p>[Last Fold]: When the power is turned on, the machine starts up with the setting contents of the last time the machine was used in effect. However, [Detection] starts up set as turned on, and the adjustment value of folding plate 1 and 2 return to the initial value when not saved.</p> <p>After setting, an icon () is displayed on the touch panel display section.</p> <p>[Stopper Fixed]: The settings of the control panel can be omitted when folding is always performed in the same conditions.</p> <p>When this mode is set, the machine is always automatically set to the same conditions when the power is turned on and initial operation of folding plate is no longer performed.</p> <p>[Stopper Fixed] is automatically set to same conditions, therefore the folding mode or paper size cannot be changed.</p> <p>However, [Detection] starts up set as turned on.</p> <p>The adjustment value of folding plate 1 and 2 returns to the initial value when it is not saved.</p> <p>After setting, an icon () is displayed on the touch panel display section.</p>	Normal
[2]	D-Feed	 "8-4. Double-feed detection" (p.63)	OFF
[3]	Interval	Sets whether to enable the interval.	Off
[4]	Processing speed up/down key	 Chapter 1 "6-1-2. Touch panel operation section" (p.16)	Speed 5

No.	Name	Function	Default value
[5]	Processing speed display	Displays the processing speed currently set.	–
[6]	 (Return) key	Saves the setting when power is turned on and returns to the [Function Settings] screen.	–
[7]	 (Cancel) key	Returns to the [Function Settings] screen without saving the setting content. Press and hold to return to the [Ready] screen.	–
[8]	Paper size	Sets the standard paper size. (DF-990/DF-990A)	A4/LTR
[9]	Paper size display	Displays the standard paper size currently set.	–

⚠ **When the [Stopper Fixed] is set, folding misalignment in the vertical direction occurs by removing the folding plate with the power turned off. Be sure to press the  key at the same time when turning on the power, and eject the folding plate forcibly.**





8-7. Initial screen

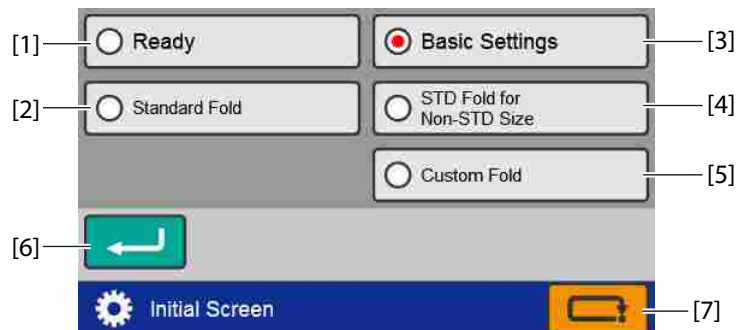

You can set the desired screen when the power is turned on according to the work situation.

Touch the  key on the [Ready] screen → Touch the  key → Touch [Initial Screen].

The [Initial Screen] screen is displayed.



No.	Name	Function	Default value
[1]	Ready	Sets the displayed screen when power is turned on to the [Ready] screen.  Chapter 1 “6-1. [Ready] screen/[Processing] screen” (p.13)	–
[2]	Standard Fold	Sets the displayed screen when power is turned on to the [Folding Mode] screen. (*1) Sets the displayed screen when power is turned on to the [Standard Size] screen. (*2)  Chapter 1 “6-4. [Folding Mode] select screen” (p.19)	–
[3]	Basic Settings	Sets the displayed screen when power is turned on to the [Basic Settings] screen.  Chapter 1 “6-2. [Basic Settings] screen” (p.18)	–
[4]	STD Fold for Non-STD Size	Sets the displayed screen when power is turned on to the [Paper Length] input screen.  Chapter 1 “6-5. [Paper Length] input screen” (p.20)	–



No.	Name	Function	Default value
[5]	Custom Fold	Sets the displayed screen when power is turned on to the [Custom Fold] screen. ☞ Chapter 1 “6-9. [Custom Fold] screen” (p.23)	–
[6]	 (Return) key	Saves the settings of the screen when power is turned on and returns to the [Function Settings] screen.	–
[7]	 (Cancel) key	Returns to the [Function Settings] screen without saving the input content. Press and hold to return to the [Ready] screen.	–

(*1) DF-999/DF-999A

(*2) DF-990/DF-990A

8-8. Custom screen

You can add custom keys to display the screen you want to move immediately to from the top screen. However, the screen is not displayed when stopper fixed mode or manual feed mode is set.

Touch the  key on the [Ready] screen —> Touch the  key —> Touch the [Custom Screen].

The [Custom Screen] screen is displayed.

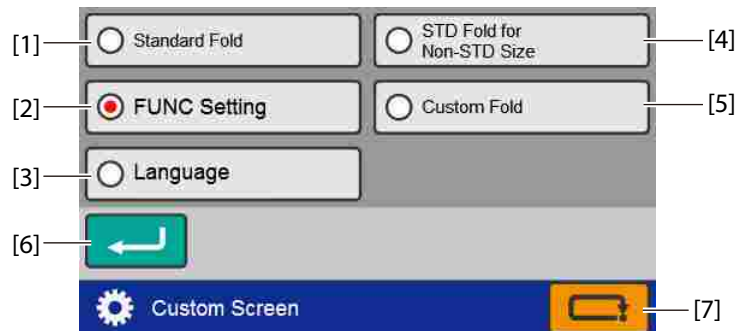

No.	Name	Function	Default value
[1]	Standard Fold (*1)	DF-999/DF-999A: The [Folding Mode] screen of [Standard Fold] is displayed. However, when automatic paper size detection is turned off, the [Standard Size] screen is displayed. DF-990/DF-990A: The [Folding Mode] screen of [Standard Size] is displayed.	–
[2]	Function Settings (*1)	The [Function Settings] screen is displayed.	–
[3]	Language (*2)	The [Language] setting screen is displayed. Chose your language.	–
[4]	STD Fold for Non-STD Size (*1)	The [Paper Length] input screen of [Standard Fold for Non-Standard Size] is displayed.	–
[5]	Custom Fold (*1)	The saved data selection screen of [Custom Fold] is displayed.	–
[6]	 (Return) key	Saves the setting of the custom screen and returns to the [Function Settings] screen.	–



No.	Name	Function	Default value
[7]	 (Cancel) key	Returns to the [Function Settings] screen without saving the input content. Press and hold to return to the [Ready] screen.	–

(*1) The screen is not displayed when the machine is set in stopper fixed mode or manual feed mode.

(*2) This screen is displayed in any setting modes.



8-9. Idling

When double feed or mis-feed occurs, or when interrupting paper folding processing during operation by pressing the  key, it is possible to set whether to keep operation of the machine standing by under idling conditions without stopping operations other than conveyance drive.

Touch the  key on the [Ready] screen → Touch the  key → Touch the  key → Touch the [Idling].

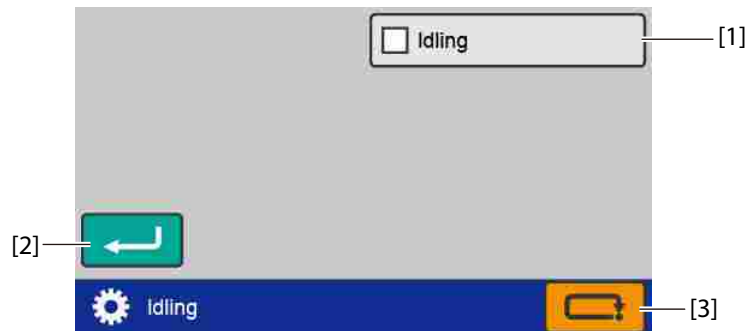
The [Idling] screen is displayed.



No.	Name	Function	Default value
[1]	Idling	Set on/off of idling.	Off
[2]	 (Return) key	Saves the idling setting and returns to the [Function Settings] screen.	–
[3]	 (Cancel) key	Returns to the [Function Settings] screen without saving the input content. Press and hold to return to the [Ready] screen.	–

 Idling operation will stop when the control panel is not operated more than 30 seconds in the idling state.

Press the  key to stop the machine during idling.



8-10. Tone

The buzzer (key operational sound on the control panel) or not can be set.
The buzzer sounds with the setting off when a trouble has occurred.

Touch the  key on the top screen —> Touch the  key —> Touch the  key —> Touch the [Tone].

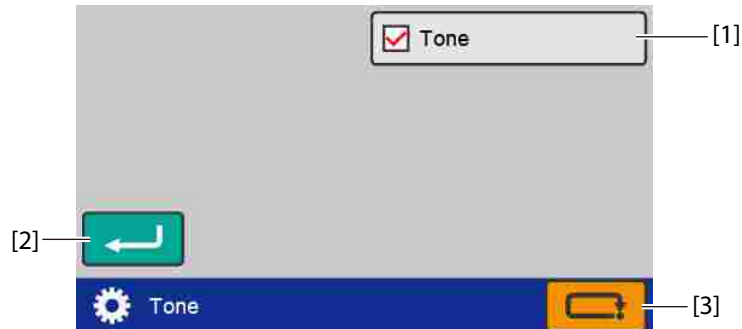

The [Tone] screen is displayed.



No.	Name	Function	Default value
[1]	Tone	Set on/off of the tone.	On
[2]	 (Return) key	Saves the tone setting and returns to the [Function Settings] screen.	-
[3]	 (Cancel) key	Returns to the [Function Settings] screen without saving the input content. Press and hold to return to the [Ready] screen.	-



8-11. mm/inch

According to the usage environment, units of numerical input saved for the paper size, folding dimensions (folding stopper adjustment value), and custom folding can be changed.

Touch the  key on the [Ready] screen —> Touch the  key —> Touch the  key —> Touch the [mm/inch].

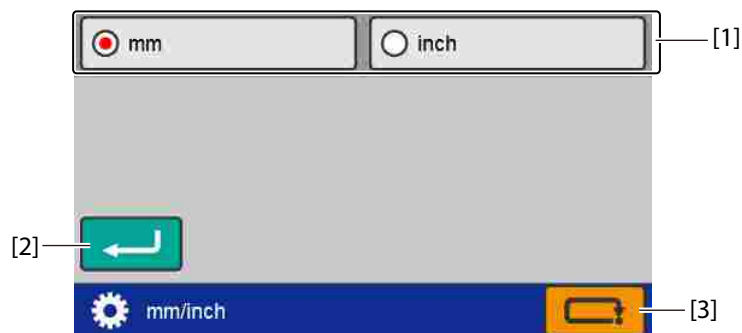
The [mm/inch] screen is displayed.



No.	Name	Function	Default value
[1]	mm/inch	Sets the display unit of the dimension values.	mm (For EU) inch (For NA)
[2]	 (Return) key	Saves the mm/inch setting and returns to the [Function Settings] screen.	–
[3]	 (Cancel) key	Returns to the [Function Settings] screen without saving the input content. Press and hold to return to the [Ready] screen.	–



8-12. LCD bright

Set the brightness of the backlight of the LCD touch panel section.

Touch the  key on the [Ready] screen → Touch the  key → Touch the  key → Touch the [LCD Bright].

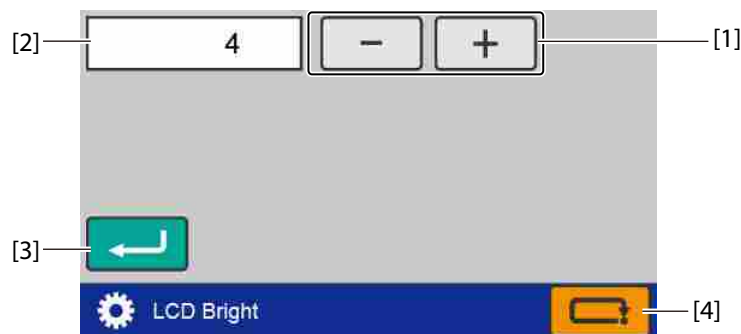

The [LCD Bright] screen is displayed.



No.	Name	Function	Default value
[1]	Screen brightness adjustment key	Sets the brightness of the backlight. [+]: Makes the screen brighter. When the set value is at the upper limit, the key is grayed out and cannot be operated. [-]: Makes the screen dimmer. When the set value is at the lower limit, the key is grayed out and cannot be operated. Setting range: 1 to 5	4
[2]	Screen brightness display	Displays the values currently set.	–
[3]	 (Return) key	Saves the screen brightness setting and returns to the [Function Settings] screen.	–
[4]	 (Cancel) key	Returns to the [Function Settings] screen without saving the input content. Press and hold to return to the [Ready] screen.	–



8-13. Number of test sheets

The number of sheets is set when performing test feeding.

Touch the  key on the [Ready] screen → Touch the  key → Touch the  key → Touch the [Number of Test Sheets].

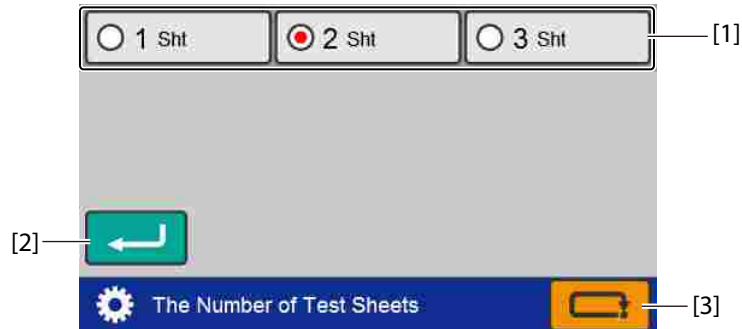

The [Number of Test Sheets] screen is displayed.



No.	Name	Function	Default value
[1]	Number of test sheets setting	Sets the number of test feed sheets. Setting range: 1 to 3	2
[2]	 (Return) key	Saves the number of test sheets setting and returns to the [Function Settings] screen.	-
[3]	 (Cancel) key	Returns to the [Function Settings] screen without saving the input content. Press and hold to return to the [Ready] screen.	-



8-14. Language

Changes the language displayed on the touch panel. However, the language setting returns to the initial setting when the power is turned off.

Touch the  key on the [Ready] screen → Touch the  key → Touch the  key → Touch the [Language].

The [Language] screen is displayed.



No.	Name	Function	Default value
[1]	Select the language	Selects the language displayed on the touch panel.	English
[2]	 (Return) key	Saves the number of test sheets setting and returns to the [Function Settings] screen.	-
[3]	 (Cancel) key	Returns to the [Function Settings] screen without saving the input content. Press and hold to return to the [Ready] screen.	-



8-15. Power saving

Set the time for the backlight of the LCD touch panel section to automatically turn off when the machine is not used for a certain time.

Touch the  key on the [Ready] screen → Touch the  key → Touch the  key → Touch the [Power Save].

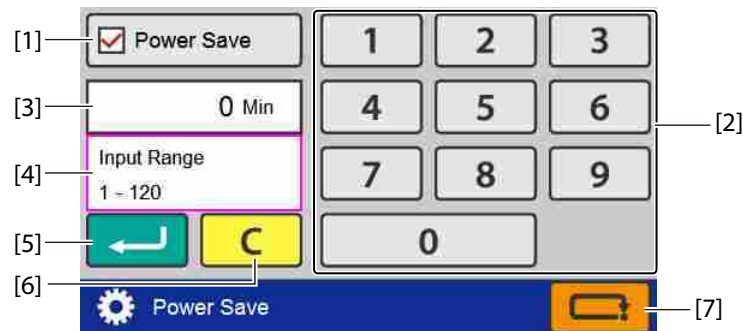
The [Power Save] screen is displayed.





No.	Name	Function	Default value
[1]	Power Save	Set on/off of the power saving function.	On
[2]	Numeric keypad	Inputs the value. When the power saving setting is turned off, the key is grayed out and cannot be operated. Input range: 1 to 120 (minutes)	1
[3]	Power saving time display	Displays the time currently set.	-
[4]	Input range display.	Displayed when trying to input a value that exceeds the input range.	-
[5]	 (Return) key	Saves the power saving setting and returns to the [Function Settings] screen.	-
[6]	 (Clear) key	Sets the input value to "0". When the power saving setting is turned off, the key is grayed out and cannot be operated.	-
[7]	 (Cancel) key	Returns to the [Function Settings] screen without saving the input content. Press and hold to return to the [Ready] screen.	-

8-16. Alarm (DF-999/DF-999A)

When this machine remains unused for the specified period of time, the buzzer sounds to remind that the power remains turned on.



When the [Alarm] setting is turned on, a buzzer sounds when the set time is reached.

When the machine is not operated after the alarm sounds, the alarm will continue to sound every 1 minute.

Touch the  key on the [Ready] screen → Touch the  key → Touch the  key → Touch the [Alarm].

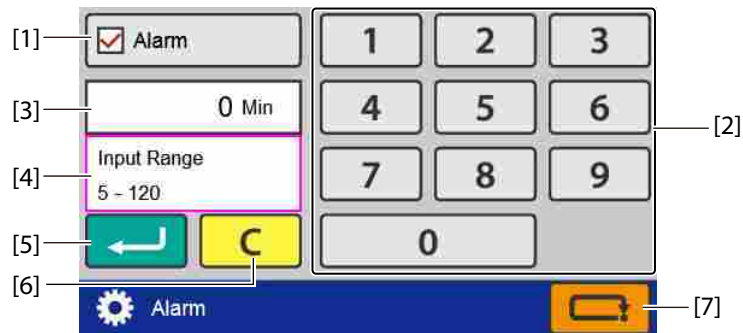
The [Alarm] screen is displayed.



No.	Name	Function	Default value
[1]	Alarm	Set on/off of the alarm.	Off
[2]	Numeric keypad	Inputs the value. When the alarm setting is turned off, the key is grayed out and cannot be operated. Input range: 5 to 120 (minutes)	60
[3]	Alarm time display	Displays the time currently set.	-
[4]	Input range display	Displayed when trying to input a value that exceeds the input range.	-
[5]	 (Return) key	Saves the alarm setting and returns to the [Function Settings] screen.	-
[6]	 (Clear) key	Sets the input value to "0". When the alarm setting is turned off, the key is grayed out and cannot be operated.	-
[7]	 (Cancel) key	Returns to the [Function Settings] screen without saving the input content. Press and hold to return to the [Ready] screen.	-

Chapter 4 Using the DF HAND FEED KIT

At maximum three sheets of paper can be simultaneously folded together by using the DF HAND FEED KIT.

1. Applicable Paper and Folding Mode

1-1. Paper to be used

Paper size: A4,B5 (For EU)/LTR (For NA)

Thickness of paper: 52.3 to 81.4 g/m²/35.56 to 55.35 lbs

The number of paper to be folded: Maximum three sheets of paper. Fine quality short grain paper 64 g/m²/43.52 lbs or less, art paper, two sheets of coated paper or less



- **Do not use a smaller type of paper than specified. Paper jam may occur inside this machine by using other type of paper and a trouble may be caused.**
- **The number of sheets out of the range above cannot be processed, and thinner or thicker sheets cannot be used. Deformed folding may be performed, and paper jam may occur in this machine by processing more sheets, or using thinner or thicker sheets than specified, and a trouble may be caused.**

1-2. Folding modes

- Single fold
- Letter fold
- Accordion-fold

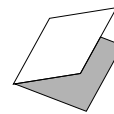

Single fold

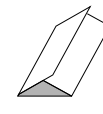

Letter fold

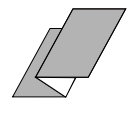

Accordion-fold



When performing letter fold of thick paper, the folded paper opens at the ejecting section, and it cannot be conveyed under the stacker roller, which may result in an error.

Using A3 or B4 size single folded paper (cross fold)

Cross fold is available only for a single fold sheet. More than one sheet of single fold paper cannot be used.

Press the folded section firmly and perform paper folding operation. The paper feeding state will be unstable if the folded line is not folded firmly.



- Folded paper may result in Σ dent depending on the paper type and stretch of the folded section. This is not a malfunction of the machine.
- When folding single-folded paper by manual feeding, folding may not be completed properly depending on the paper thickness and stiffness at the folded section. Check in advance using the paper to be used.

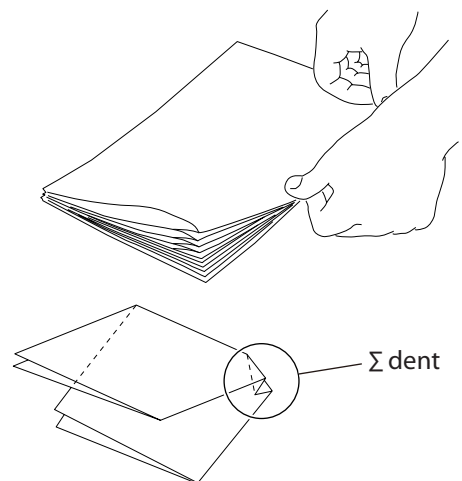

Performing Gate Fold with the DF HAND FEED KIT Attached

When the DF HAND FEED KIT is attached, the switching axis position of this machine will be changed. Due to this, when performing gate fold by automatic paper feeding, the folding line of second folding tends to double-fold (as shown in the figure). This is not a malfunction of the machine.

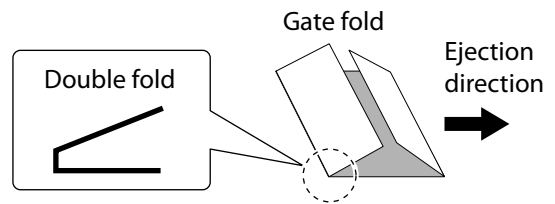

2. Staples

Applicable range of folding of stapled paper is limited.

2-1. Usable staplers

Use the flat type stapler as the staples are stitched evenly.

! When using a stapler other than specified item, the staples touch the folding roller, and do not enter between the folding rollers, or cannot process paper folding as the staples touch the inlet of the folding plate.

Do not use any other staplers than specified as they injure the folding roller.



Flat type staples



Glasses type staples

2-2. Usable staples

[a] Use a staple No. 10 (Max No10-1M), standard item. The length of staple: width of 8.4 mm/0.33 inch, and height of 5.0 mm/0.20 inch.

[b] Use a flat type stapler the height of which is 1.5 mm/0.05 inch or less in the stapled state.

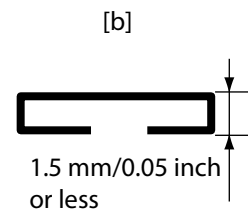
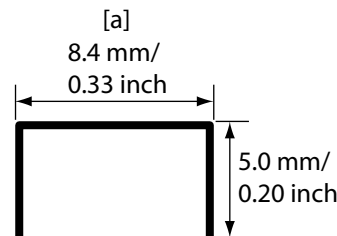

2-3. Stitching with stapler

Stitch the paper with stapler in parallel with the paper.

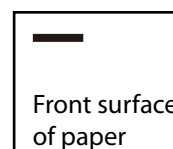

Front surface of paper

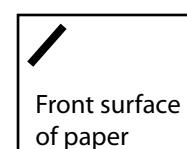

Front surface of paper

Stitching position is within 20 mm/0.78 inch or less from the edge of paper.

- ! **When the upper-left corner of the paper is stitched with the stapler, reverse the paper, and insert the paper into the inlet so that the staples will be positioned at the top right corner.**

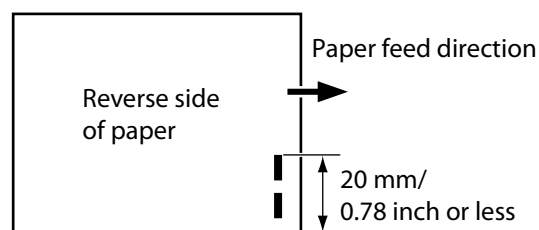

Stitching position with staples and folding style are as shown in the figure.

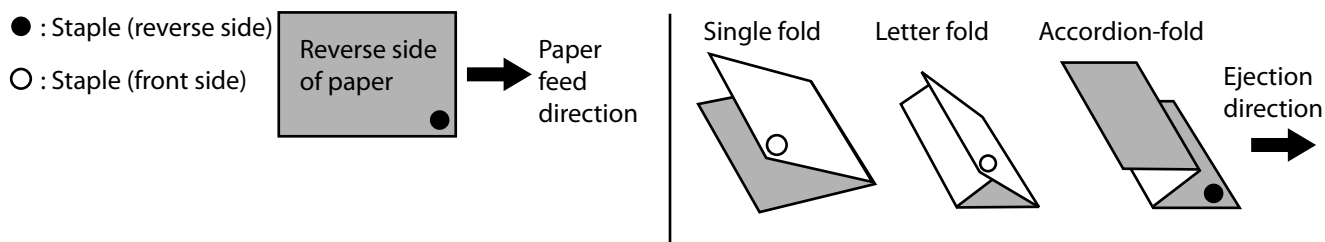

3. Manual Feed Mode Setting

Displayed only when DF HAND FEED KIT is registered as an optional item.

Touch the key on the top screen —> Touch the key —> Touch the [Manual Feed Mode].

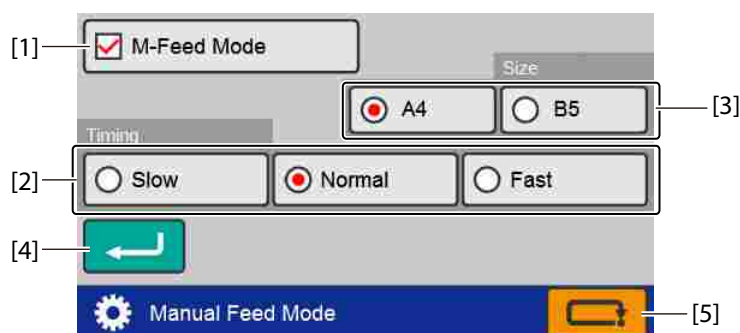

The [Manual Feed Mode] screen is displayed.



No.	Name	Function	Default value
[1]	M-Feed Mode	Set on/off of the manual feed mode.	Off
[2]	Timing	Sets the time from insertion of paper into the manual feed inlet to starting of the folding operation.	Normal
[3]	Size	Sets the paper size to be inserted manually.	A4
[4]	(Return) key	Saves the manual feed mode setting and returns to the [Function Settings] screen.	–
[5]	(Cancel) key	Returns to the [Function Settings] screen without saving the input content. Press and hold to return to the [Ready] screen.	–

4. Operation

⚠ CAUTION

-  **Do not put fingers inside during operation.**
-  **Keep away long hair, ties, jewelry and loose clothing.**
-  **It could cause injury.**

1 Open the paper receiving tray to the right side when it is seen on the operator's side.

2 Attach the auxiliary paper ejection guide to the stacker roller.

3 Set [Manual Feed Mode].

 "3. Manual Feed Mode Setting" (p.77)

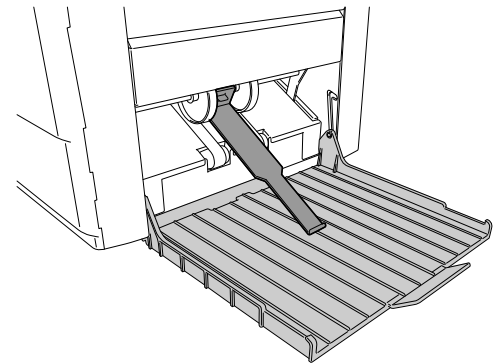

! When running thick sheets, set a speed to higher levels. Low speeds may cause abnormal folds.

4 Set the paper to the hand feed paper feed guide of the hand feed paper feed tray.

! Do not insert the paper into the inlet. Inserting paper into the inlet will result in paper jam or injury as the sensor detects and the paper is fed.

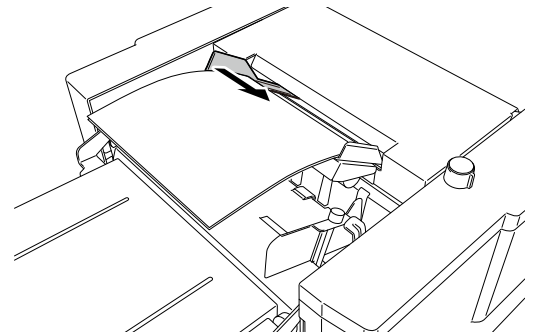

5 Set the auxiliary guide to the paper side.

! Set the auxiliary guide leaving some clearance between the guide and paper. Too much pressure may cause a paper feed error such as mis-feed, etc.

6 Insert a sheet of paper to perform test folding.

Insert paper into the inlet, and the machine will start feeding operation automatically to process folding.

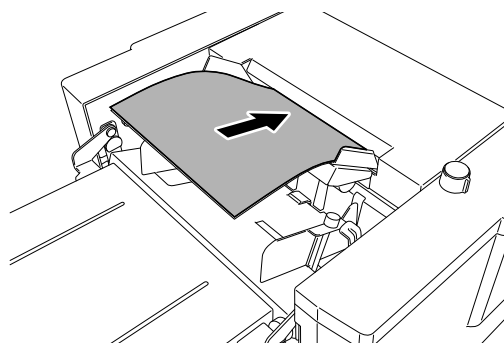

- ! **Compress the paper inside the machine to insert paper into the inlet. If the paper is not compressed enough, paper jam may occur. If so, press the $\sqrt{\text{O}} \rightarrow$ key to eject paper forcibly.**

7 Check the finish of test folding.

Adjust the folding misalignment as required.

8 Select the method of using the counter. (Count Up and Count Down)

Chapter 2 "3. Standard Folding of Standard Paper" (p.36)

9 Insert paper to start folding operation.

- !
 - **Do not insert the next paper before the machine stops. If the next paper is inserted before the machine stops, [Jam Feed Sec] is displayed on the LCD touch panel, and the machine stops.**
When an error is displayed, press the $\sqrt{\text{O}} \rightarrow$ key to force ejection.
 - **When removing paper from the inlet after the machine starts paper feeding operation, it is determined that paper is fed inside the machine, [Jam Conveyance Sec] is displayed on the LCD touch panel, and the machine stops.**
If so, cancel the error by taking either of the following measures. Press the $\sqrt{\text{O}} \rightarrow$ key to force ejection.

5. Correcting Folding Misalignment

CAUTION

- Do not put fingers inside during operation.**
- Keep away long hair, ties, jewelry and loose clothing.**
- It could cause injury.**

5-1. Adjustment folding misalignment in up and down direction

Chapter 3 "1-2. Adjustment folding misalignment in up and down direction" (p.43)

5-2. Adjustment folding misalignment in right and left direction

If folding misalignment occurs in the right and left direction when performing hand feed operation, adjust with the manual skew correction knob.

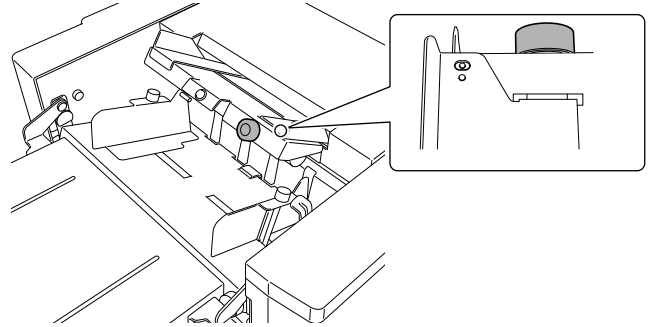

☞ Chapter 3 “1-1. Adjustment folding misalignment in right and left direction” (p.42)

5-3. Abnormal folding

If abnormal folding occurs, check the following points.

- Do not use paper outside the specifications.
Particularly, deformed folding occurs frequently in the use of thin, flimsy paper not appropriate.
- Use paper with grains of long grain.
(if the paper with grains of short grain is used, the number of sheets to be used is up to 2 sheets.)
- If the paper curls, flatten the paper to use.
- Set the auxiliary guide leaving a small clearance between the guide and paper.
- Use the stapler and staples as specified. Do not use any other staplers and staples which are not specified.

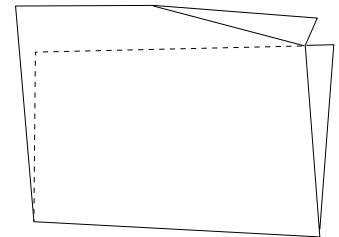

Chapter 5 Cleaning the Machine

- Make sure that you disconnect the power cord from the wall outlet before cleaning.
- Before you use the machine after cleaning, make sure that its surface is completely dry.

⚠ CAUTION



Do not use flammable sprays and solvents during cleaning, etc. of internal parts of the machine and in the vicinity of the machine.



Doing so could cause build-up of gas inside the machine, which in turn could cause ignition, resulting in fire and explosion.



When using alcohol, exercise precaution against fire and ventilate well, and after use, store in a safe place.

Use of other solvents may damage the rubber rollers and resin inside the machine, resulting in malfunction.

⚠ WARNING



Open or close the top cover gently.

Hands or fingers may be caught in the cover section. Doing so may result in injury.

1. Cleaning paper feed rings and folding rollers

Open the top cover.

Paper feed ring

Clean with a cloth moistened with alcohol rotating the paper feed ring by hand.

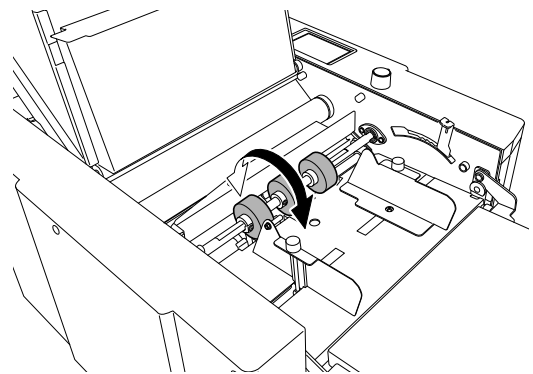

Folding roller

- 1 Remove the folding plate 1.**
- 2 Clean with a cloth moistened with alcohol rotating the jam correction knob.**

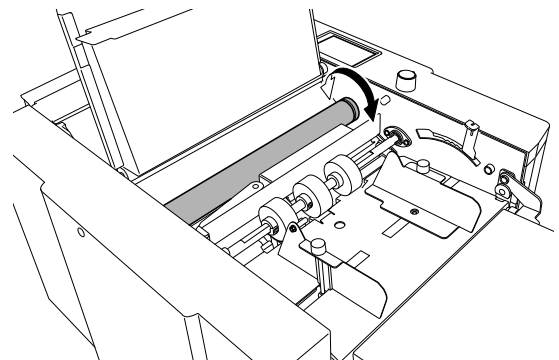

2. Cleaning sensor

If the sensor is dirty, the detection function may not work properly.
Keep in mind the following notes when using the air duster.



- Use a non-flammable air duster. Read the cautions for use well, and be sure to keep the descriptions in mind.
- The sensors and metallic section are cooled by gas in the air duster, and may be temporarily condensed. Wait for about five minutes.

Paper feed timing sensor (up and down), paper sensor, double-feed detection sensor (up and down)

1 Open the top cover.

2 Remove dust with an air duster.

- [1] Paper feed timing sensor upper
- [2] Paper sensor
- [3] Double-feed detection sensor (up and down)
Ultrasonic sensor (up and down) (option)

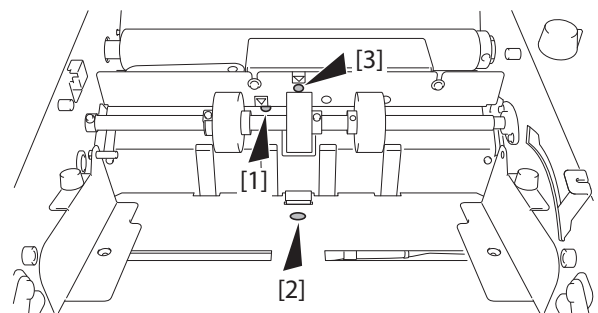

Paper ejection jam sensor upper

Remove dust with an air duster.

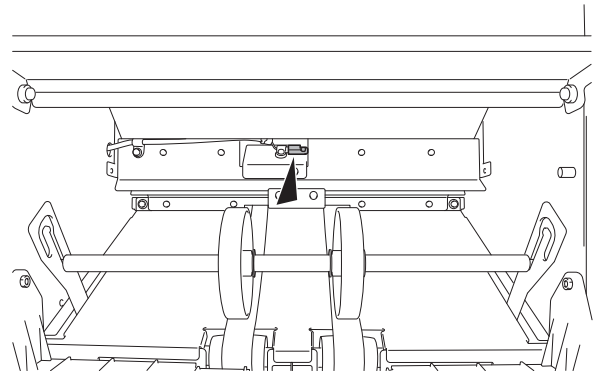

Paper ejection jam sensor lower

1 Open the side cover.

2 Remove the folding plate 2.

3 Remove dust with an air duster or wipe with a dry cloth.

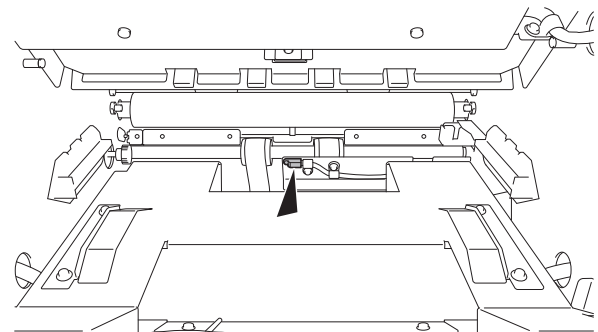

3. Cleaning LCD touch panel

Gently wipe the LCD touch panel of the control panel with a dry cloth.

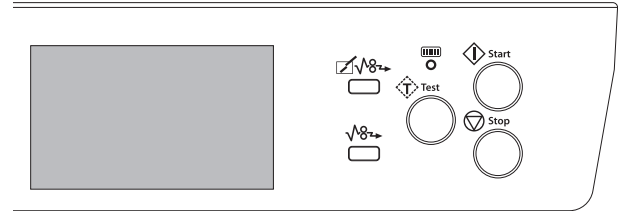

4. Cleaning stacker belt

- 1** Remove the auxiliary paper ejection guide.
- 2** Wipe the stacker belt with a cloth moistened with alcohol while rotating it by hand.

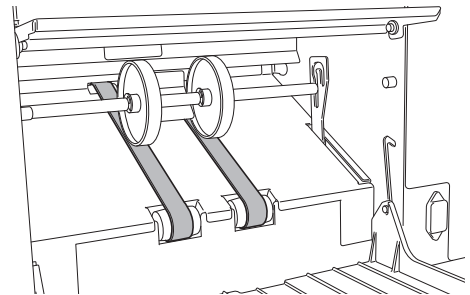

5. Cleaning paper separator

When the paper separator is dirty, mis-feed or double-feed may occur, and paper feeding cannot be normally performed.

For the cleaning of paper separator, contact Duplo dealer.

Chapter 6 Trouble Guide

1. Error Code

Check the error code or error message and solve the problem by following the guide displayed on the screen or by referring to list below. If the error cannot be solved by the following methods, contact your dealer.

Depending on the content of the error, the **C** key might not be displayed.

If the **C** key is displayed, check the guide content and touch the **C** key to release the error.

If the **C** key is not displayed, follow the guide content to release the error.

1-1. Warning error

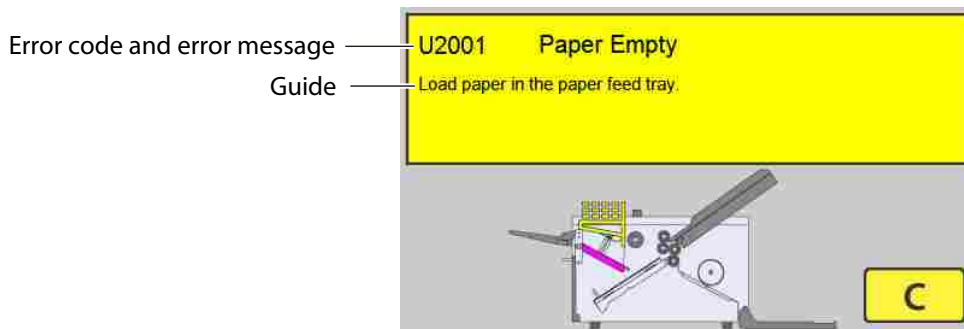

Error Code	Cause	Solution
U1000	The top cover is open.	Close the top cover.
U1300	The side cover is open.	Close the side cover after attaching the folding plate 2 correctly.
U1500	Folding plate 1 is not attached.	Attach the folding plate 1 correctly.
U1602 (*1)	The  key is pressed in a state where test paper feeding is not performed when the optical sensor is set for double feed detection.	Perform a test feed.
U2001	Paper is not stacked in the paper feed tray.	Load paper in the paper feed tray. Touch the C key to release the error.
U2005 (*1)	The direction of paper stacked on the paper feed tray is incorrect.	Load paper in the correct direction. Check if the paper size setting is correctly set. Touch the C key to release the error.
U2007 (*2)	The paper feed tray is not set.	Raise the paper feed tray. Touch the C key to release the error.

(*1) DF-999/DF-999A

(*2) DF-990/DF-990A





1-2. Motor error

Follow the guide content to solve the error.

Error code and error message

Guide



Error Code	Cause	Solution
E2002 (*)	Abnormal stack on the motor for raising and lowering paper feed plates due to paper jamming, etc.	Remove jammed paper and touch the  key to release the error.
E2003 (*)		
E2005 (*)		
E2220	Abnormal stack on the motor due to paper jamming, etc.	
E2221		
E2400	Abnormal stack on the stacker roller motor due to paper jamming, etc.	Remove jammed paper and touch the  key to release the error.
E2401		
E2402		
E2409		
E2410	Folding plate 1 is not attached properly.	Make sure that folding plate 1 is attached properly.
E2411		
E2412	Motor for moving the folding stopper is not functioning due to paper jamming, etc.	Remove jammed paper and touch the  key to release the error.
E2419		
E2420	Folding plate 2 is not attached properly.	Make sure that folding plate 2 is attached properly.
E2421		
E2422	Motor for moving the folding stopper is not functioning due to paper jamming, etc.	Remove jammed paper and touch the  key to release the error.
E2429		

(*) DF-999/DF-999A

1-3. Paper jam error

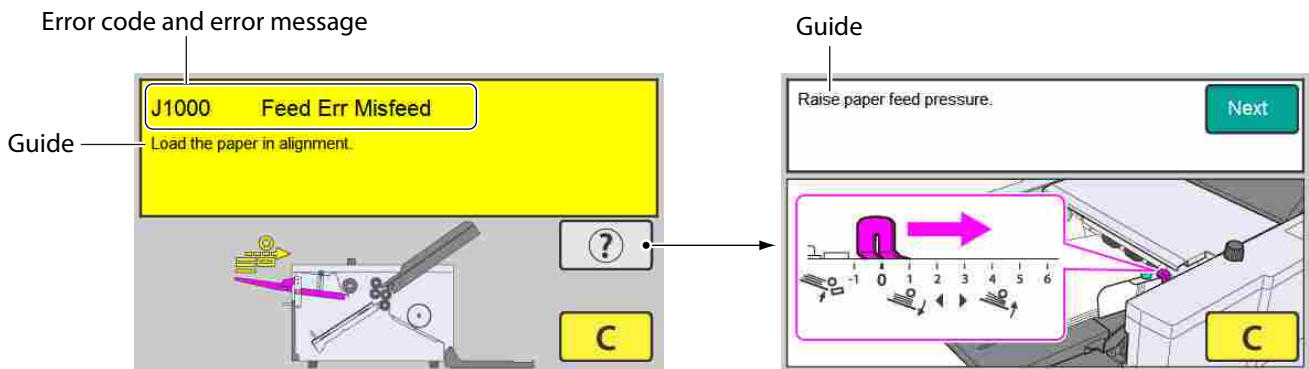

If the same error occurs frequently even when the error is solved by following the guide content, touching the key displays an illustration and guide on how to respond to the error content.

Error Code	Cause	Solution
J1000	Miss-feed on the paper feed tray.	Align the paper again.
J1001	Double-feed occurs at the paper feed section.	Remove the double-fed paper.
J1006	Paper jamming at paper feed section.	Remove the jammed paper.
J3002	Paper jamming inside the machine.	Remove the jammed paper. Clear the error by referring to forcible ejection or opening and closing the top cover.
J6002	Paper jamming at paper ejecting section.	Remove the jammed paper.

1-4. Other errors

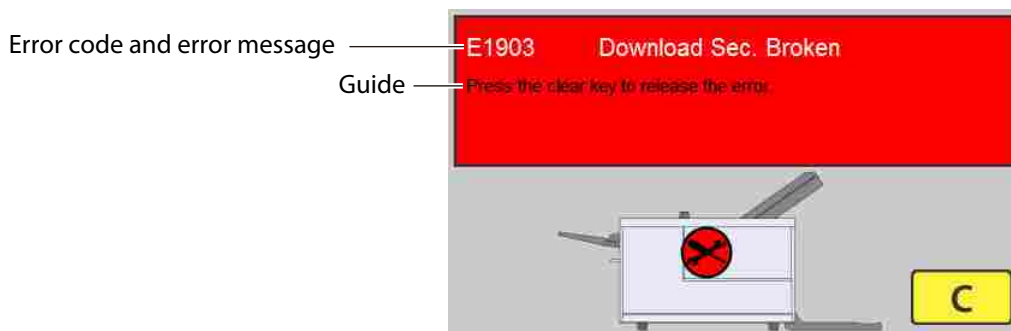

Error Code	Cause	Solution
E1903	An incorrect program is included.	Touch the key to release the error.
E1904	Incorrect data is included in the SD card.	

1-5. Errors requiring a service call

When the following error codes are displayed, turn the power off and on. If the error is not cleared, contact Duplo dealer.

E1101
E1902
E4210
E4300
E4301
E4302
E5011
E5012
E5013
E5015
E5770

2. Paper Jam

! CAUTION



Do not put fingers inside during operation.
Keep away long hair, ties, jewelry and loose clothing.
It could cause injury.

! WARNING



Open or close the top cover gently.

Hands or fingers may be caught in the cover section. Doing so may result in injury.

When paper jams, remove the paper in the following way.

2-1. Paper feed ring

- 1** Open the top cover.
- 2** Remove slowly the jammed paper near the paper feed ring.
- 3** Close the top cover.

 If paper cannot be pulled out easily, first remove all the paper on the paper feed tray and pull out the jammed paper.

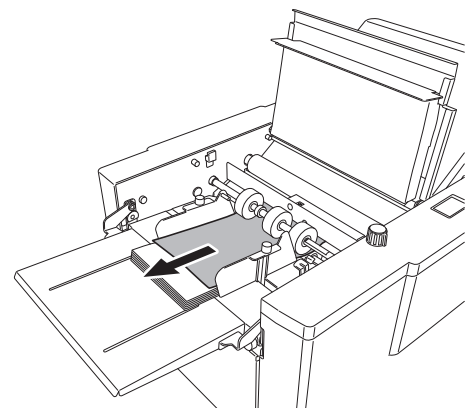

2-2. Folding roller

1 Take out the folding plate 1.

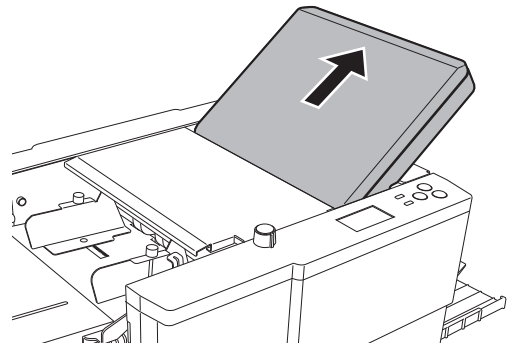

2 Open the side cover.

3 Take out the folding plate 2.

4 Open the top cover.

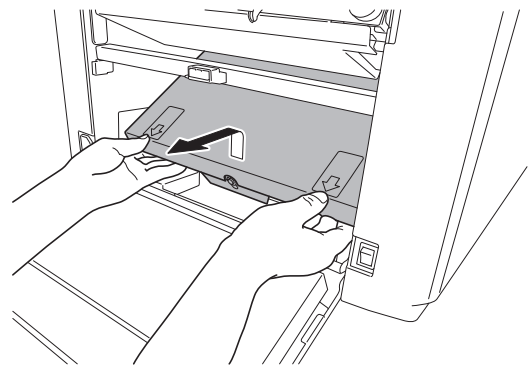

5 Pull out the paper rotating the jam correction knob.

6 Close the top cover.

7 Insert the folding plate 1 and folding plate 2.

☞ Chapter 1 "2-3. Installation procedures" (p.5)

8 Close the side cover.

The side cover will not be closed if the folding plate 2 is not attached correctly.

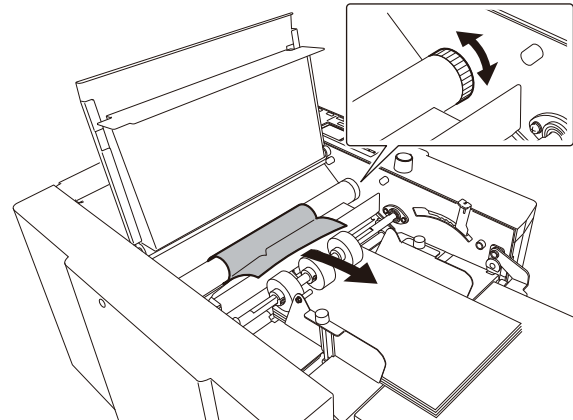

2-3. Folding plate

Press the  key.

Eject forcibly the paper inside the folding plate.

Forcible ejection in the folding plate will not stop until the folding stopper returns to the home position, as the folding stopper moves, even if the key is not held.

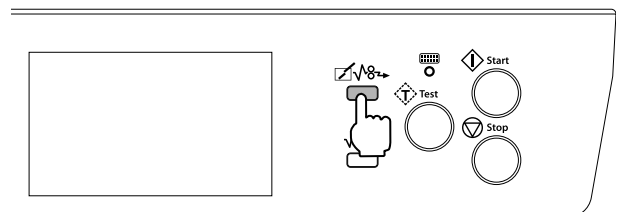

Even if the paper is not removed after forcible ejection, check the position of paper jam to remove the paper with the following method.

Folding plate 1

- 1 Take out the folding plate 1.
- 2 Remove the jammed paper.

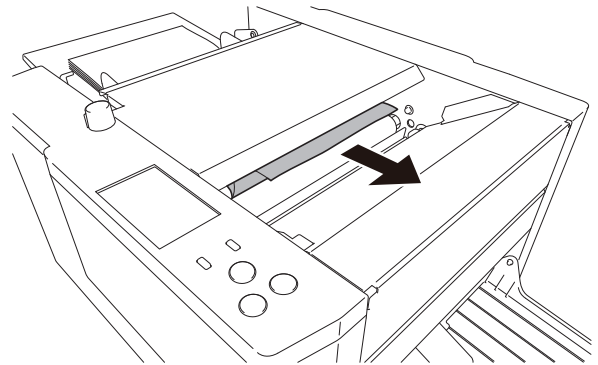

Folding plate 2

- 1 Open the side cover.
- 2 Take out the folding plate 2.

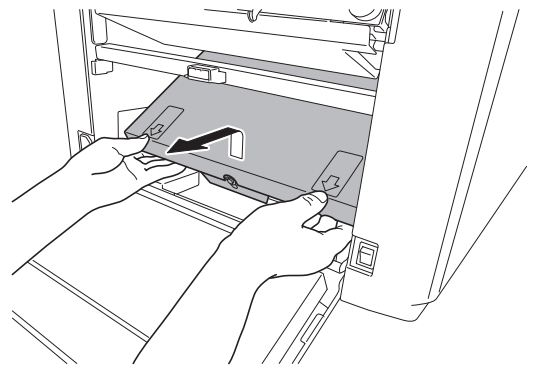

- 3 Open the top cover.
- 4 Pull out the paper rotating the jam correction knob.
- 5 Close the top cover.

- 6 Insert the folding plate 2.
 Chapter 1 "2-3. Installation procedures" (p.5)

- 7 Close the side cover.
 The side cover will not be closed if the folding plate 2 is not attached correctly.

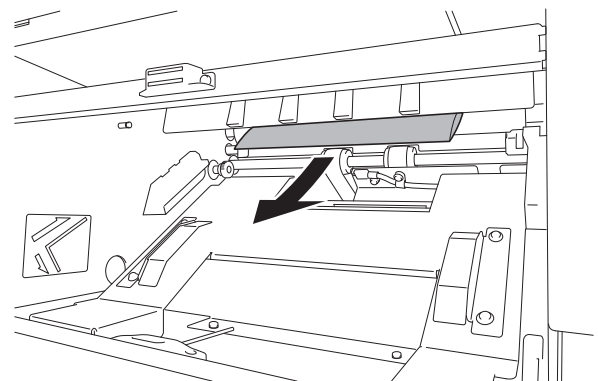

2-4. Ejecting section

Press the $\sqrt{8} \rightarrow$ key.

The paper is forcibly ejected.

Paper is ejected forcibly as long as the key is held down. Forcible ejection will stop by releasing the key.

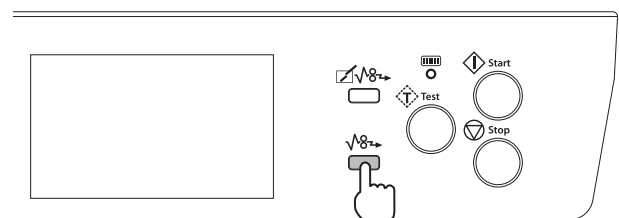



3. Troubleshooting

⚠ WARNING



Do not use a flammable static electricity removal spray.
 Doing so could cause build-up of gas inside the machine, which in turn could cause ignition, resulting in fire and explosion.

Condition	Cause	Solution
Power is not turned on.	The power cord is not connected.	Connect the power cord. (p.8)
	The power switch is not turned on.	Turn on the power switch. (p.33)
The machine does not start operation when the  key is pressed.	Paper is not stacked.	Stacking paper on the paper feed tray. (p.34)
	The paper switch is not responding.	Stacking paper in correct position so that the paper switch responds. (p.34)
	Paper has jammed.	Remove jammed paper. (p.87)
	The top cover and side cover are open.	Close the covers which are open. (The side cover will not be closed if the folding plate 2 is not attached correctly.)
	Non-standard paper is used in standard paper settings. (DF-999/DF-999A)	Change the settings to match non-standard paper.
	The paper feed guide is off the paper size detection area. (DF-999/DF-999A)	Secure the paper feed guide correctly.
	The paper set lever is not lowered. (DF-990/DF-990A)	Lower the paper set lever.
	[D-Feed Detect] is turned on but test folding was not performed. (DF-999/DF-999A)	Perform test folding.
	A6, A7, B7 or other non-standard paper is used. (For EU)	Input the paper size. (p.58)
The folding stopper of folding plate 1 or 2 does not operate.	The folding plates 1 and 2 are not set properly.	Set the folding plates 1 and 2 properly. (p.5)
Paper is not folded at the normal folding position.	The folding plates 1 and 2 are not set properly.	Set the folding plates 1 and 2 properly. (p.5)
	Static electricity is built up on paper.	<ul style="list-style-type: none"> • Use a commercially available static electricity removal spray. • Separate the paper well. (p.30) • Humidify with a humidifier as required.
Paper jam occurs.	Paper is not separated well.	Separate the paper well. (p.30)
	Paper is curled.	Correct the paper curl before use. (p.30)
	The folding roller is stained.	Clean with a cloth moistened with alcohol. (p.81)
	The stacker roller is not positioned correctly.	Re-set the position of the stacker roller. (p.59)
	Static electricity is built up on paper.	<ul style="list-style-type: none"> • Use a commercially available static electricity removal spray. • Separate the paper well. (p.30) • Humidify with a humidifier as required.

Condition	Cause	Solution
Double-feed of paper has occurred.	Paper feed pressure is too high.	Decrease the paper feed pressure. (p.36)
	Paper separating pressure is too low.	Increase the paper separating pressure. (p.36)
	The paper separator is stained.	For the cleaning of paper separator, contact Duplo dealer.
	Paper is sticking and difficult to separate.	Check that the printing ink of the paper has dried and there is no static electricity, and then separate the paper well. (p.30)
	Paper out of specifications is used.	Do not use paper outside the specifications.
	Paper is not separated before being stacked.	Separate the paper enough. (p.30)
	Ink is not dried.	Dry the paper enough. (p.30)
	Paper is not stacked in alignment.	Stack the paper in alignment. (p.30)
	Loaded paper is more than 46 mm/1.81 inches in height.	Stacking paper so that it is less than 46 mm/1.81 inches in height.
	Paper thickness is not appropriate.	Repeat test folding after checking paper thickness.
Mis-feed of paper has occurred.	Paper feed pressure is too low.	Increase the paper feed pressure. (p.36)
	Paper separating pressure is too high.	Decrease the paper separating pressure. (p.36)
	The paper feed ring is stained.	Clean with a cloth moistened with alcohol. (p.81)
	Paper is sticking and difficult to separate.	Check that the printing ink of the paper has dried and there is no static electricity, and then separate the paper well. (p.30)
	Paper out of specifications is used.	Do not use paper outside the specifications.
	Paper is not separated before being stacked.	Separate the paper enough. (p.30)
	Ink is not dried.	Dry the paper enough. (p.30)
	Paper is not stacked in alignment.	Stack the paper in alignment. (p.30)
	The paper feed guide is pressed against the paper too strong.	Set the paper feed guide so that it touches the paper lightly. (p.34)
	Folding misalignment along the vertical length of the paper occurs.	Processing speed was changed midway through operation.
Paper type (quality, thickness) was changed midway through operation.		
The folding plate was removed while the stopper fixed mode was ON.		Attach the folding plate and then press the  key.
Folding misalignment along the sides of the paper occurs.	Too many sheets of paper are stacked.	Reduce the paper amount.
	The paper feed guides are not set properly.	Set the paper feed guides properly. (p.42)
	The fixing screws of the paper feed guides got loose and the paper feed guide slipped out of position.	Tighten the fixing screws of the paper feed guides. (p.42)
	Paper is not cut properly.	Correct the folding misalignment along the sides of the paper using the skew correction knob. (p.42)

Condition	Cause	Solution
Continuous-feeding occurs with small paper.	Paper out of specifications is used.	Do not use paper outside the specifications.
	Paper feed pressure is too high.	Decrease the paper feed pressure. (p.36)
	The separating pressure is too low.	Increase the separating pressure. (p.36)
	The paper feed guides are not set properly.	Set the paper feed guide according to the paper. (p.34)
	Paper is not properly aligned.	Align the paper well before stacking on the paper feed tray. (p.30)
	Thin flimsy paper is used.	Lower the processing speed. (p.36)
	Paper size with limitations in processing speed is used.	
Single-folded thick paper jams at the folding rollers.	Paper out of specifications is used.	Do not use paper outside the specifications.
	Paper feed pressure is too high.	Decrease the paper feed pressure.
	The processing speed is too slow.	Increase the processing speed. (p.61)
	Paper is not separated well.	Separate the paper well. (p.30)
When large paper is stacked on the paper feed tray, the tray does not rise even when the  key is pressed.	Too many sheets of paper are stacked.	Reduce the paper amount.
	Heavy paper is used.	Increase the paper feed pressure. (p.36)
Mis-detection of double-feed occurs.	Test folding is not carried out after the paper is re-stacked.	Perform test folding whenever new sheets of paper are re-stacked. Repeat test folding when a miss-feed or double-feed error occurs.
	Paper thickness in the double-feed detection setting is not appropriately set.	Check the paper thickness, change the setting of paper thickness to [Thick] and test fold again.
	The printing state is variable within the range of double-feed detection.	Set the double-feed detection to off. (p.63) (At this time, double-feed is not detected.)
Mis-detection of mis-feed occurs.	Paper is fed askew.	Align paper appropriately and stack the paper at a proper position. (p.34)
	Double-feed detection is set to on, the paper thickness is not appropriate.	Check the paper thickness, change the setting of paper thickness to [Thin] and test fold again.
The machine will not start operation even though the paper is inserted from the hand feed inlet.	[Manual Feed Mode] is set to off.	Set [Manual Feed Mode] to on. (p.77)
	Small amount of paper is inserted into the hand feed inlet.	Insert paper into the hand feed inlet as far as it goes.
Paper is fed unstably in cross fold.	Folding line is not firmly pressed.	Press the folding line firmly. (p.51)
Folding mis-alignment has occurred in cross fold.	Folding line is not firmly pressed.	Press the folding line firmly. (p.51)
	Paper stacking height exceeds 25 mm/0.98 inch.	Set the paper stacking height to 25 mm/0.98 inch or less. (p.51)
	The auxiliary paper feed ring (for moving) is not set on the folding line.	Set the auxiliary paper feed ring (for moving) on the folding line. (p.51)
	The cross fold lever is not attached.	Attach the cross fold lever. (p.51)
Mis-feed has occurred in cross fold.	Paper feed pressure is low.	Set the paper feed pressure to [3] or more using the feed pressure adjustment lever.

Chapter 7 Appendix

1. Specifications

Design and specifications are subject to change without notice.

Basic specifications

Model			DF-999/DF-999A	DF-990/DF-990A
Item	Unit			
Paper feed tray paper loading capacity	mm		46 (*1)	
	inch		1.8 (*1)	
Power supply	Voltage	V	100 - 240	
	Frequency	Hz	50/60	
Current consumption		A	1.0 - 0.5	
Power consumption		W	100	
Airborne noise	Conditions		With the machine placed on the table with the height of 0.6 m/23.62 inches, measured at a distance of 1 m/39.37 inches from the control panel and at a height of 1.55 m/61.03 inches from the floor. Noise test EN13023 J.3.1.1 – Grade 3 – Paper quality: Fine quality paper 81.4 g/m ² /55.35 lbs (Vertical) – Paper size: A4 – Processing speed: 6 – Folding mode: Single fold	
	Equivalent continuous A-weighted sound pressure level (L _{Aeq}) (*2)	dB	71	72
	Sound pressure level at peak (L ^{pC})		90	92
Dimensions (W x D x H)	When used	mm	1,046 x 512 x 494	
		inch	41.19 x 20.16 x 19.45	
	When stored	mm	665 x 512 x 494	
		inch	26.19 x 20.16 x 19.45	
Mass	kg		41.6 (*3)/43.0 (*4)	40.6 (*3)/42.0 (*4)
	lb.		91.8 (*3)/94.8 (*4)	89.6 (*3)/92.6 (*4)
Options	Model/Name of product		DF HAND FEED KIT/KIT DF ULTRASONIC SENSOR KIT/ KIT	DF HAND FEED KIT/KIT

- (*1) Fine quality paper 64 g/m²/43.52 lbs (Equivalent to 500 sheets)
Cross folding shall be 25 mm/0.98 inch or less
- (*2) * L_{Aeq} is the value added consideration of the variation with time to the A-weighted sound pressure level L_{pA}.
- (*3) Machine weight (Main body + Folding plate 1 + Folding plate 2)
- (*4) Including accessories (1.0 kg/2.2 lb)

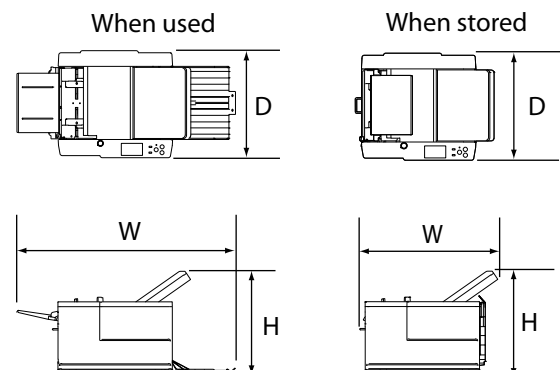

Media

Model			DF-999/DF-999A	DF-990/DF-990A
Item		Unit		
Paper size (W x L)	Maximum	mm	311 x 457.2 (*1)	
		inch	12.24 x 18.0 (*1)	
	Minimum	mm	74 x 105 (*1)	
		inch	2.91 x 4.14 (*1)	
	Standard paper	EU	A3/B4/A4/B5/A5/B6	
		NA	LGR (double letter)/LGL (legal)/LTR (letter)/STMT (statement)/INV (invoice)	
Paper type			Sheet Single fold	
Paper quality (thickness)	Fine quality paper	g/m ²	46.5 to 157.0 (*2)	
		lbs	31.62 to 106.76 (*2)	
	Art paper/coated paper	g/m ²	84.9 to 127.9 (*3)	
		lbs	57.73 to 86.97 (*3)	

- (*1) For paper that is less than 128 mm/5.04 inches (length direction), the following conditions apply.
 Paper quality: Fine quality paper 64 to 81.4 g/m²/43.52 to 55.35 lbs
 Processing speed: 3 to 4 speed
 Paper jogging at the paper exit stacker section shall not be considered.
- (*2) Depending on the paper manufacturing conditions, groundwood paper, stencil paper, recycled paper and medium quality paper are outside the specifications.
 Confirm using the folding test.
- (*3) Paper feed tray stacking height is 25 mm/0.98 inch or less.
 Depending on the paper manufacturing conditions, it will be outside the specifications.
 Confirm using the folding test.

Performance and functions

Model			DF-999/DF-999A	DF-990/DF-990A
Item	Unit			
Processing speed	Maximum	Sheets/min.	260 (*1)	
Folding form (*2)			Single fold/Double fold/Irregular accordion fold/Letter fold/ Accordion fold/Gate fold (*3)/Specified cross fold (*4)/ Other deformed folding (*5)	
Folding speed adjustment (*6)	5 speed	Sheets/min.	242	
	6 speed		260	

- (*1) Paper quality: Fine quality paper 81.4 g/m²/55.35 lbs (Vertical)
Paper size: A4 (lengthways)
Folding mode: Single fold
- (*2) The type of folding modes available may be limited depending on the paper quality and size.
Only single fold is applicable to thick paper 157 g/m²/106.76 lbs or heavier and larger than B4.
Double fold or irregular accordion fold-out of B6 paper is only applicable for 64 g/m²/43.52 lbs paper.
However, only under the condition that processing speed is set to 4 or faster, and folding dimension B is 47 mm or more.
Only single fold is applicable to 157 g/m²/106.76 lbs paper under low temperature conditions (20°C/68°F or below).
- (*3) Short grain paper of 64 g/m²/43.52 lbs or less cannot be used. The paper length also has to be 432 mm/17.00 inches or less.
- (*4) Fine quality paper 52.3 to 104.7 g/m²/35.56 to 71.20 lbs
- (*5) The maximum folded length of paper folded has to be 230.0 mm/9.05 inches or less.
- (*6) Paper quality: Fine quality paper 81.4 g/m²/55.35 lbs (Vertical)
Paper size: A4
Folding mode: Single fold
Standard setting range: 1 to 6 speed (1 to 6)
Thin paper mode: 0 speed (1-)
Thick paper mode: 7 speed (6+)

Option specifications

Model			DF ULTRASONIC SENSOR KIT
Item	Unit		
Paper quality			Fine quality paper (*)
Paper type			Sheet
Paper size(W x L)	mm	100.0 x 148.0 to 311.0 x 457.2	
	inch	3.93 x 5.83 to 12.24 x 18.0	

- (*) 46.5 to 157 g/m²/31.62 to 106.76 lbs

Duplo Corporation

www.duplo.com

4-1-6 Oyama, Chuo-ku, Sagamihara-shi, Kanagawa 252-5280, Japan

TEL: +81-42-775-3602

FAX: +81-42-775-3606

E-mail: info@duplo.com

Duplo

Copyright © 2019 Duplo Corporation All Rights Reserved

18H-90040-0
19030000D